

MUTATION AND THE COLORED JONES POLYNOMIAL

ALEXANDER STOIMENOW AND TOSHIFUMI TANAKA

*BK21 Project, Department of Mathematical Sciences,
KAIST, Daejeon 307-701, Republic of Korea*

*Pohang Mathematics Institute, POSTECH
San 31, Hyojadong, Namgu, Pohang, Kyungbuk 790-784, Republic of Korea*

stoimeno@mathsci.kaist.ac.kr, tanakat@postech.ac.kr

with appendices by Daniel Matei and the first author

ABSTRACT. It is known that the colored Jones polynomials, various 2-cable link polynomials, the hyperbolic volume, and the fundamental group of the double branched cover coincide on mutant knots. We construct examples showing that these criteria, even in various combinations, are not sufficient to determine the mutation class of a knot, and that they are independent in several ways. In particular, we answer negatively the question of whether the colored Jones polynomial determines a simple knot up to mutation.

AMS Classifications: 57M25, 57N70

Keywords: Mutation; Jones polynomial; fundamental group; double branched cover; concordance

1. INTRODUCTION

Mutation, introduced by Conway [Co], is a procedure of turning a knot into another, often different but “similar” one. This similarity alludes to the circumstance, that most of the common (efficiently computable) invariants coincide on mutants, and so mutants are difficult to distinguish. A basic exercise in skein theory shows that mutants have the same Alexander polynomial Δ , and this argument extends to the later discovered Jones V , HOMFLY(-PT or skein) P , BLMH Q and Kauffman F polynomials [J, F&, LM, BLM, Ho, Ka]. The cabling formula for the Alexander polynomial (see for example [Li, theorem 6.15]) shows also that Alexander polynomials of all satellite knots of mutants coincide, and the same was proved by Lickorish and Lipson [LL] also for the HOMFLY and Kauffman polynomials of 2-satellites of mutants. The HOMFLY polynomial applied on a 3-cable can generally distinguish mutants (for example the K-T and Conway knot; see §3.2), but with a calculation effort that is too large to be considered widely practicable.

While the Jones polynomial, unlike Δ , was known not to satisfy a cabling formula (because it distinguishes some cables of knots with the same polynomial), nonetheless Morton and Traczyk [MT] showed that Jones polynomials of all satellites of mutants are equal. As a follow-up to this result, the question was raised (see [Kr, problem 1.91(2)]; Question 3.1 below) whether the converse is true for simple knots. A slightly stronger paraphrase is: Is the Jones polynomial of all satellites in fact a *universal* satellite mutation invariant, i.e. does it distinguish all knots which are not mutants or satellites of mutants?

Since the Jones polynomial of all satellites is (equivalent to) what is now known as the “colored Jones polynomial” (CJP), such a universality property relates to some widely studied, known or conjectural, features of this invariant. Two important recent problems in knot theory, the AJ [Ga2] and Volume conjectures [MM], assert that the CJP determines the A -polynomial resp. the Gromov norm. Besides, it was proved (as conjectured by Melvin and Morton) that it determines the Alexander polynomial [BG, Ch, KSA, Va], and evidence is present that it determines the signature function [Ga]. The latter problem

would be settled, at least for simple knots, by the aforementioned universality property of the CJP, since it is known (see [CL]), that mutation preserves all signatures. Since Ruberman [Ru] showed that mutants have equal volume in all hyperbolic pieces of the JSJ decomposition, universality would imply too (a qualitative version of) the Volume conjecture. It is also consistent with the AJ-conjecture and a recent result of Tillmann [Ti, corollary 3] on coincidence of some factors of A -polynomials of mutants. Note also that the Volume conjecture¹, as well as the AJ-conjecture [DG], in turn imply that the colored Jones polynomial, and hence Vassiliev invariants [BN], detect the unknot.

The main motivation for this paper is to answer negatively the aforementioned question (Question 3.1) regarding the possible universal satellite mutation invariance of the CJP.

Theorem 1.1. *There exist infinitely many pairs of (simple) hyperbolic knots with equal CJP, which are not mutants.*

Below we will show constructions of knots with equal colored Jones polynomial. The exclusion of mutation in Theorem 1.1 is based on a study of Vassiliev invariants obtained from (cabled) knot polynomials. Apart from providing such examples, we will examine closer various other criteria for mutation. We will use also a different concept, representations of the fundamental group of the double branched cover (contributed by Daniel Matei in an appendix to our paper). Either of the Vassiliev invariant and the group representations approach may be more useful than the other, as we show by examples. In contrast, we give in §4 also instances where CJP excludes mutation, but other invariants (knot polynomials, hyperbolic volume) fail. Some of our arguments are followed by several remarks. These try to address the relation of our examples to the AJ- and Volume conjecture, as well as combinations of mutation criteria for which we do not know if (non-)distinction phenomena occur. The conclusions of our work can be summed up like this (see Remark 3.8, Examples 4.1 and 5.3, and Theorem 4.2):

Theorem 1.2.

- (1) *The CJP does not determine the HOMFLY, Kauffman polynomial or their 2-satellites, or the fundamental group of the double branched cover.*
- (2) *The CJP of hyperbolic knots is not determined by hyperbolic volume, the double cover, the HOMFLY, Kauffman polynomial and 2-cable HOMFLY polynomial, even when all of them are taken in combination.*
- (3) *The property two hyperbolic knots to be mutants is not determined by the coincidence (even in combination) of hyperbolic volume, CJP, HOMFLY, Kauffman polynomial and either (a) their 2-satellites or (b) the double cover.*

A brief outline of the paper is as follows. After §2, containing some preliminaries on the Colored Jones polynomial, we will start in §3 with some examples to prove Theorem 1.1. These, and many of the following, examples grew out of the first author's attempt to determine the mutations among low crossing knots [St]. In §4 we study some pairs consisting of a knot and its mirror image, and then further refine the construction for and proof of Theorem 1.1 to adapt it to such pairs (see Theorem 4.2). We have, however, also cases, where the polynomial invariants fail. These examples are shown in §5. For such knots the exclusion of mutation was extremely difficult, and we were assisted by Daniel Matei. He explains his calculation in the first appendix of the paper.

The second appendix was added subsequently and contains the proof of an extension of Theorem 1.1, due to the first author. In a separate paper [St9], he was able to resolve the problems in computations remaining open here. With this the table of mutants up to 15 crossings could be completed.

2. THE COLORED JONES POLYNOMIALS OF KNOTS

2.1. Satellites. First we set up and clarify some terminology concerning satellites.

Let L be a link embedded in the solid torus $T = S^1 \times D^2$. If we embed T in S^3 so that its core $S^1 \times \{0\}$ represents a knot K , then we call the resulting embedding K' of L the *satellite of (companion) K with pattern L* . The satellite is defined up to the choice of framing of T . The *algebraic intersection number*

¹The second author [T] has shown that it is in fact sufficient that the Volume conjecture holds for doubled knots.

$d_a(L)$ of L is its absolute homology class in $H_1(T) = \mathbb{Z}$. The *geometric intersection number* $d_g(L)$ of L is the smallest number of transverse intersection points of L with a meridional disk D of T . Clearly $d_g(L) \geq d_a(L)$ for any L . If K' is a satellite with pattern L , we call the number $d_g(L)$ also the *degree* of K' .

If $d_a(L) = d_g(L)$ (i.e. all the intersections of D with L can be made so that L points in the same direction w.r.t. D), then we call the satellite K' also a *cable* of K . This notion differs at some other places. Often the term cable is understood to refer only to (p, q) -cables, i.e. those satellites whose pattern is a torus link. More generally, cables are sometimes called satellites with braid patterns L , i.e. such with $|L \cap (\{z\} \times D^2)| = d_a(L)$ for all $z \in S^1$. Our definition is more relaxed than either of those.

A cable K' of K is called *connected* if K' (or the pattern L) is a knot, and *standard*, if $L = S^1 \times \{x_1, \dots, x_n\}$, with x_i being distinct points in D^2 . A satellite/cable of degree n is simply called an n -satellite or n -cable. If L is one of the components of the Whitehead link, and T the complement of the other component, then we call K' a *Whitehead double* of K .

To simplify language, let us call a *satellite of the Jones polynomial* an invariant of knots K obtained by evaluating the (ordinary) Jones polynomial on a satellite of K . (In other words, we dualize the satellite operation on the level of invariants.)

2.2. Definition of the CJP. Let $\mathbb{Z}[A, A^{-1}]$ be the Laurent polynomial ring in one indeterminate A with coefficients in the ring of integers. We put $q = a^2 = A^4$ (so that $q = 1/t$ for the variable t of the Jones polynomial standardly used), and set $\{n\} = a^n - a^{-n}$, $[n] = \{n\}/\{1\}$ and $[n]! = [1][2] \dots [n]$.

The *Kauffman bracket skein module* $\mathcal{K}(M)$ of an oriented 3-manifold M is the quotient of the free $\mathbb{Z}[A, A^{-1}]$ -module generated by the set of ambient isotopy classes of framed links in M , by the following *Kauffman relations*:

$$\langle L \amalg \bigcirc \rangle = -[2] \langle L \rangle, \quad \langle \times \rangle = A \langle \smile \rangle + A^{-1} \langle \frown \rangle$$

We know that $\mathcal{K}(S^3)$ can be identified with $\mathbb{Z}[A, A^{-1}]$. The *Kauffman bracket* $\langle L \rangle \in \mathbb{Z}[A, A^{-1}]$ of a framed link L in S^3 is defined by the image of the isomorphism $\mathcal{K}(S^3) \rightarrow \mathbb{Z}[A, A^{-1}]$ which takes the empty link \emptyset to 1.

The skein module of the solid torus $T = S^1 \times D^2$ is $\mathbb{Z}[A, A^{-1}][z]$. Here z is given by the framed link $S^1 \times I$, where I is a small arc in the interior of D^2 , and z^n means n parallel copies of z . Put $\mathcal{B} = \mathcal{K}(T)$. There is a basis $\{\mathbf{e}_i\}_{i \geq 0}$ for \mathcal{B} which is defined recursively by

$$(1) \quad \mathbf{e}_0 = 1, \mathbf{e}_1 = z, \mathbf{e}_i = z\mathbf{e}_{i-1} - \mathbf{e}_{i-2}.$$

Let K be a knot in S^3 . We assume that K is equipped with the zero framing. We define a $\mathbb{Z}[A, A^{-1}]$ -linear map $\langle \rangle_K: \mathcal{B} \rightarrow \mathbb{Z}[A, A^{-1}]$ for K by cabling K and taking the Kauffman bracket. The *N -colored Jones polynomial* of a knot K is defined as the Kauffman bracket of K cabled by $(-1)^N \mathbf{e}_N$:

$$J'_K(N; A) = (-1)^N \langle \mathbf{e}_N \rangle_K.$$

It is then normalized

$$J_K(N; A) = \frac{J'_K(N; A)}{J'_\bigcirc(N; A)},$$

so that it takes value 1 on the unknot.

This invariant is the quantum invariant corresponding to the $N + 1$ -dimensional representation of sl_2 . As in §1, we continue using the abbreviation CJP.

2.3. Graphical calculus for the CJP. Now we explain the graphical calculus of G. Masbaum and P. Vogel [MV] (or see also [BHMV]).

Let $\mathbb{Q}(A)$ be the field generated by the indeterminate A over the rational numbers \mathbb{Q} . Framed (n, n) -tangles with Kauffman relations generate a finite-dimensional associative algebra T_n over $\mathbb{Q}(A)$, which is called the *Temperley-Lieb algebra on n -strings*. T_n is generated by the following elements.

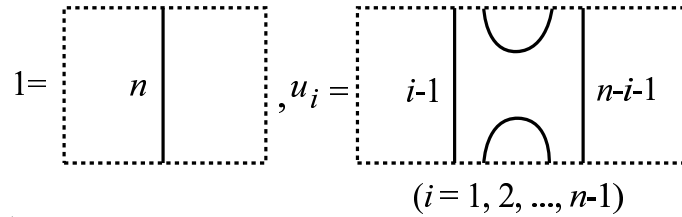

An integer beside an arc signifies n copies of the arc all parallel in the plane. There is a *trace map* $g : T_n \rightarrow \mathcal{B}$ given by mapping a tangle with square to the diagram in the annulus obtained by identifying the upper and lower edges of the diagram. If we put $d_n = g(f^{(n)})$, where $f^{(n)}$ is the *Jones-Wenzl idempotent* in T_n , then it is well known that $\{d_j\}_{j \geq 0}$ satisfies the recurrence formula for $\{e_i\}_{i \geq 0}$. So the basis $\{e_i\}_{i \geq 0}$ can be defined by using the Jones-Wenzl idempotent and the trace map.

An *admissibly colored framed (or ribbon) trivalent graph* is defined as follows. A *color* is just a nonnegative integer. A triple of colors (a, b, c) is *admissible* if it satisfies the following conditions:

- $a + b + c$ is even, and
- $a + b \geq c \geq |a - b|$, as well as the analogous two other inequalities obtained by permuting a, b, c .

Let D be a planar diagram of a ribbon trivalent graph. An admissible coloring of D is an assignment of colors to the edges of D so that at each vertex, the three colors meeting there form an admissible triple.

The Kauffman bracket of an admissibly colored framed trivalent graph D is defined to be the Kauffman bracket of the expansion of D obtained as follows. The expansion of an edge colored by n consists of n parallel strands with a copy of the *Jones-Wenzl idempotent* $f^{(n)}$ inserted and the colored vertices are expanded as in Figure 1.

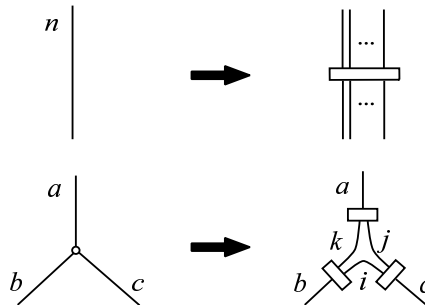

Figure 1

The Jones-Wenzl idempotent $f^{(n)}$ is characterized by the property that $u_i f^{(n)} = f^{(n)} u_i = 0$ for each u_i ($1 \leq i \leq n - 1$) and $(f^{(n)})^2 = f^{(n)}$. The idempotent is represented by a little box. The triple (a, b, c) is admissible. The *internal colors* i, j, k are defined by

$$(2) \quad i = (b + c - a)/2, \quad j = (a + c - b)/2, \quad \text{and} \quad k = (a + b - c)/2.$$

Now we can regard $\langle e_n \rangle_K$ as a planar diagram of a ribbon trivalent graph by writing n beneath K and inserting a little box into K .

This way, the colored Jones polynomial J_K of a knot K can be considered as a sequence of polynomials $\{J_K(N; A)\}_{N \in \mathbb{N}}$ in A , associated to natural numbers N . These polynomials are obtained by evaluating

the Jones polynomial on a cable of K , decorated with the Jones-Wenzl idempotent. So $J_*(N; A)$ are linear combinations of satellites of the Jones polynomial. For $N = 1$ we have the Jones polynomial V itself.

It is known (and can be deduced from the shape of the elements e_N of (1)) that the information contained in all satellites of the Jones polynomial is equivalent to the colored Jones polynomial. Moreover, for the lowest N distinguishing two knots, it is equivalent whether we talk of the N -cabled or N -colored polynomial.

We put, with i, j, k as in (2),

$$\langle k \rangle = (-1)^k [k + 1], \quad \langle a, b, c \rangle = (-1)^{i+j+k} \frac{[i + j + k + 1]! [i]! [j]! [k]!}{[i + j]! [j + k]! [i + k]!}.$$

Then G. Masbaum and P. Vogel showed the following “fusion” formula [MV]:

$$(3) \quad \begin{array}{c} | \\ \square \\ | \end{array} \begin{array}{c} | \\ \square \\ | \end{array} \begin{array}{c} a \\ b \end{array} = \sum_c \frac{\langle c \rangle}{\langle a, b, c \rangle} \begin{array}{c} \diagup \quad \diagdown \\ a \quad b \\ | \\ c \\ | \\ a \quad b \\ \diagdown \quad \diagup \end{array},$$

where the sum runs over c so that (a, b, c) is admissible.

This formula will enable us to show that certain CJP are equal, though it requires to find a convenient diagram presentation of the knots (and the concrete evaluation of the polynomials remains highly uninviting).

3. MUTATIONS AND INVARIANCE OF THE COLORED JONES POLYNOMIAL

In this section we present the basic examples needed for the proof of Theorem 1.1.

3.1. Initial examples. A *mutation* (in Conway’s original² sense [Co]) is the following operation. Consider a knot being formed from two tangles T_1 and T_2 . (A tangle is understood here to consist of two strings.) Cut the knot open along the endpoints on each of the four strings coming out of T_2 . Then rotate T_2 by π along some of the 3 axes - horizontal in, vertical in, or perpendicular to the projection plane. This maps the tangle ends onto each other. Finally, glue the strings of $T_{1,2}$ back together (possibly altering orientation of all strings in T_2). Two knots K_1 and K_2 are *mutants* if they can be obtained from each other by a sequence of mutations.

A knot which is the connected sum of two non-trivial knots is called *composite*. We say that a knot K' is a *satellite knot* if it is a satellite of degree at least 2 around some knot K . (Note that a knot K' , which is a satellite of degree 1 around K , is either equal to K , or the connected sum of K with some other knot.) A knot K is called *simple* if it is not a composite or satellite knot, or in other terms, if its complement has no incompressible tori. By Thurston’s work [Th, Th2], such a knot is hyperbolic or a torus knot.

The central motivation of this paper was the following question of Przytycki. We will answer it negatively by two different pairs of examples (Figures 2 and 3).

Question 3.1. (Problem 1.91(2) in [Kr]). Let K be a simple unoriented knot. Are there any knots other than mutants of K , which cannot be distinguished from K by the Jones polynomial and all its satellites?

The knots 14_{41721} and 14_{42125} from [HT] are depicted in Figure 2. (In the following we use the knot ordering in [HT] throughout, but we append non-alternating knots of given crossing number after the alternating ones, and we do not take care of mirror images, unless it is relevant.) These are ribbon knots, and have trivial Alexander polynomial. 14_{41721} and 14_{42125} have the same HOMFLY and Kauffman

²There are now various extensions of this concept, also to 3-manifolds; see e.g. [CL, R].

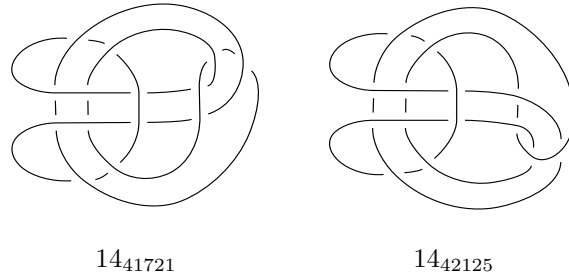

Figure 2

polynomial invariants, the same 2-cable HOMFLY polynomial, and the same hyperbolic volume (see Remark 3.7 below). For this pair of knots, we show the following.

Proposition 3.2. 14_{41721} and 14_{42125} are not mutants.

Proposition 3.3. 14_{41721} and 14_{42125} have the same colored Jones polynomial.

Propositions 3.2 and 3.3 combinedly give the first examples answering Question 3.1.

A remark on methodology is in place. Note that, by skein theory, for given strand orientation we need to calculate the HOMFLY polynomials P of two degree-2 satellites to ensure with certainty that the polynomials of all degree-2 satellites (of the given strand orientation) coincide. (In opposition, for the Jones polynomial one satellite for an arbitrarily chosen orientation suffices in any degree.) For 2-cable we used the knots obtained by the blackboard framing from the diagram D in the table of [HT] and its mirror image $!D$, both 2-cables having one negative half-twist crossing. For Whitehead double we used the (framed) satellites of D and $!D$ with a positive clasp. (In fact, it is enough to take only one of D or $!D$, since their Whitehead double polynomials are interconvertible; see (7) below.) The case of the Kauffman F polynomial is similar, though there it is not necessary to distinguish strand orientation, and so we consider only the 2-cables.

Proof of Proposition 3.2. We consider the HOMFLY polynomial $P = P(l, m)$ in the convention of [LM]. It is chosen so that the skein relation has the form

$$(4) \quad l P(\text{crossing}) + l^{-1} P(\text{crossing}) = -m P(\text{cup}) P(\text{cap}),$$

and the unknot has unit polynomial.

Let $P_{w_+}(K) = P(W_+(K))$ be the evaluation of the HOMFLY polynomial on the 0-framed (or *untwisted*) Whitehead double $W_+(K)$ of a knot K with positive clasp. The non-mutant status of the knots in Figure 2 could be established by calculation of their P_{w_+} polynomials, shown in Table 1.

The polynomials should be read as follows. The line below the knot denotes the minimal and maximal degree in the m -variable. The coefficients in (increasing even powers of) m , which are polynomials in l , follow line by line, with the minimal and maximal degree in l recorded first and followed by the coefficients of (even powers of) l . \square

Remark 3.4. Calculation showed that the 2-cable Kauffman polynomial also distinguishes the two knots. By an easy skein argument, so will then the Whitehead double Kauffman polynomials (at least with respect to some framing).

Proof of Proposition 3.3. By making repeatedly use of the formula (3), we have

$$J_{14_{41721}}(A; N) = \sum_{k_1=0}^N \frac{\langle 2k_1 \rangle}{\langle N, N, 2k_1 \rangle} \left\langle \begin{array}{c} 2k_1 \\ \text{Diagram} \end{array} \right\rangle$$

14. 41721:

0 22

-10	8		9	57	142	174	98	3	-26	-10	1	1
-12	8	18	-40	-496	-1284	-1588	-984	-122	246	132	-10	-16
-12	8	-138	105	2229	5257	5895	3693	613	-1207	-843	0	92
-12	8	449	-253	-6064	-12412	-11763	-7097	-1346	3258	2546	88	-238
-12	8	-744	449	10297	18323	13979	7797	1633	-5010	-4098	-182	310
-12	8	680	-470	-11184	-17574	-10362	-5112	-1181	4587	3846	156	-212
-12	8	-354	277	7919	11167	4871	2016	516	-2576	-2210	-65	77
-12	8	104	-90	-3680	-4724	-1440	-466	-132	892	787	13	-14
-12	8	-16	15	1109	1313	257	58	18	-185	-169	-1	1
-12	4	1	-1	-208	-230	-25	-3	-1	21	20		
-8	4			22	23	1	0	0	-1	-1		
-8	-6			-1	-1							

14. 42125:

0 22

-10	8		9	57	142	174	98	3	-26	-10	1	1
-12	8	16	-56	-550	-1380	-1672	-984	-38	342	186	6	-14
-12	8	-136	149	2451	5745	6371	3693	137	-1695	-1065	-44	90
-12	8	449	-295	-6414	-13392	-12841	-7097	-268	4238	2896	130	-238
-12	8	-744	465	10571	19331	15237	7797	375	-6018	-4372	-198	310
-12	8	680	-472	-11298	-18148	-11176	-5112	-367	5161	3960	158	-212
-12	8	-354	277	7943	11349	5163	2016	224	-2758	-2234	-65	77
-12	8	104	-90	-3682	-4754	-1494	-466	-78	922	789	13	-14
-12	8	-16	15	1109	1315	261	58	14	-187	-169	-1	1
-12	4	1	-1	-208	-230	-25	-3	-1	21	20		
-8	4			22	23	1	0	0	-1	-1		
-8	-6			-1	-1							

Table 1: The polynomials P_{w+} for 14_{41721} and 14_{42125} .

$$\begin{aligned}
 &= \sum_{k_1=0}^N \sum_{k_2=0}^{2k_1} \frac{\langle 2k_1 \rangle}{\langle N, N, 2k_1 \rangle} \frac{\langle 2k_2 \rangle}{\langle 2k_1, 2k_1, 2k_2 \rangle} \left\langle \begin{array}{c} 2k_1 \quad 2k_1 \\ \text{Diagram} \end{array} \right\rangle \\
 &= \sum_{k_1=0}^N \sum_{k_2=0}^{2k_1} \sum_{k_3=0}^{k_1+k_2} \frac{\langle 2k_1 \rangle}{\langle N, N, 2k_1 \rangle} \frac{\langle 2k_2 \rangle}{\langle 2k_1, 2k_1, 2k_2 \rangle} \frac{\langle 2k_3 \rangle}{\langle 2k_1, 2k_2, 2k_3 \rangle} \left\langle \begin{array}{c} 2k_1 \quad 2k_1 \\ \text{Diagram} \end{array} \right\rangle,
 \end{aligned}$$

where the third sum runs over all k_3 such that $(2k_1, 2k_2, 2k_3)$ is admissible. We note that k_3 equals zero by a property of the Jones-Wenzl idempotent. In fact, if we expand the sum above and use a property described in a formula in the middle of page 368 of [MV], then we know that all terms with $k_3 \neq 0$ vanish. This implies that the term in the sum vanishes if $k_1 \neq k_2$. So we have

$$J_{14_{41721}}(A; N) = \sum_{k_1=0}^N \frac{\langle 2k_1 \rangle}{\langle N, N, 2k_1 \rangle} \frac{\langle 2k_1 \rangle}{\langle 2k_1, 2k_1, 2k_1 \rangle} \left\langle \begin{array}{c} 2k_1 \\ \text{Diagram} \end{array} \right\rangle \left\langle \begin{array}{c} 2k_1 \\ \text{Diagram} \end{array} \right\rangle.$$

By using the same method, we have

$$J_{14_{42125}}(A; N) = \sum_{k_1=0}^N \frac{\langle 2k_1 \rangle}{\langle N, N, 2k_1 \rangle} \frac{\langle 2k_1 \rangle}{\langle 2k_1, 2k_1, 2k_1 \rangle} \left\langle \begin{array}{c} N \\ \text{Diagram 1} \end{array} \right\rangle \left\langle \begin{array}{c} 2k_1 \\ \text{Diagram 2} \end{array} \right\rangle.$$

Comparing the two expressions above, we obtain $J_{14_{41721}}(A; N) = J_{14_{42125}}(A; N)$. \square

By using the same argument as for the previous pair we showed that 14_{41763} and 14_{42021} have the same CJP. This pair has again the same 2-cable HOMFLY polynomials, but different Whitehead double HOMFLY polynomials.

Lemma 3.5. $J_{14_{41763}} = J_{14_{42021}}$

Proof. For the proof, one needs to find suitable diagrams, as the ones shown in figure 3.

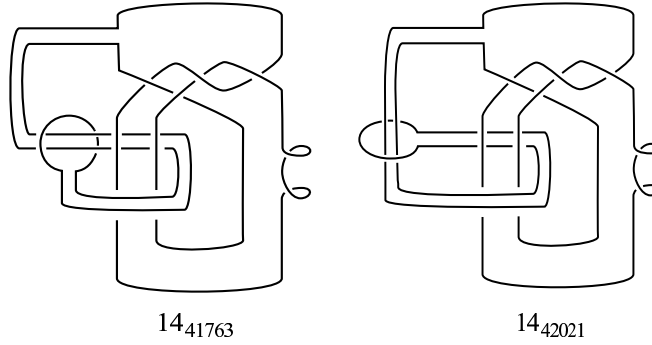

Figure 3

Then we obtain

$$J_{14_{41763}}(A; N) = \sum_{k_1=0}^N \frac{\langle 2k_1 \rangle}{\langle N, N, 2k_1 \rangle} \frac{\langle 2k_1 \rangle}{\langle 2k_1, 2k_1, 2k_1 \rangle} \left\langle \begin{array}{c} N \\ \text{Diagram 3} \end{array} \right\rangle \left\langle \begin{array}{c} 2k_1 \\ \text{Diagram 4} \end{array} \right\rangle.$$

$$J_{14_{42021}}(A; N) = \sum_{k_1=0}^N \frac{\langle 2k_1 \rangle}{\langle N, N, 2k_1 \rangle} \frac{\langle 2k_1 \rangle}{\langle 2k_1, 2k_1, 2k_1 \rangle} \left\langle \begin{array}{c} N \\ \text{Diagram 5} \end{array} \right\rangle \left\langle \begin{array}{c} 2k_1 \\ \text{Diagram 6} \end{array} \right\rangle. \quad \square$$

Both 14_{41763} and 14_{42021} are concordant to the positive trefoil knot. So we may put some weight on the following problem:

Problem 3.6. Does CJP detect a prime, simple knot modulo mutation and concordance? More exactly, are two prime, simple knots with the same CJP (a) mutants or concordant, or (b) related by a sequence of concordances (preserving the CJP) and mutations?

Remark 3.7. The invariance proof of the CJP exhibits a common pattern. Our pairs are obtained by a certain involution of a 3-string tangle, two of whose strands are parallel. In [DGST] this kind of operation

was considered as a kind of what is called a “cabled mutation”, which in turn is explained to be a special case of Ruberman’s [Ru] (2,0)-mutation. Ruberman’s work then shows why the knots in Theorem 1.1 have equal volume. It had been realized, already in [CL, page 310, line -22], that also the CJP is invariant under a (2,0)-mutation (and hence cabled mutation). Our examples turn out to be instances of this phenomenon, an insight we owe to the explanation in [DGST]. Contrarily, we stress that at least our initial pair was quoted in [DGST].

3.2. Knots with equal CJP, distinguished by HOMFLY and Kauffman polynomials. As a follow-up to Proposition 3.3, we make the following observation:

Remark 3.8. Note that the colored Jones polynomial of K determines the colored Jones polynomial of the Whitehead doubles of K . (This is clear from Kauffman bracket skein theory, but an exact formula is given in [T].) So we see that the Whitehead doubles of our pair are examples of knots with the same colored Jones polynomial but different HOMFLY and Kauffman polynomial. (See Remark 3.4, and compare also part (1) in Theorem 1.2.)

The only knots we initially thought of, which have equal CJP and are potentially distinguishable by HOMFLY and Kauffman polynomials, are 3-satellites of mutants. There have been some attempts to distinguish mutants by applying polynomials on their 3-satellites. For the HOMFLY polynomial the first such computation (and distinction) was apparently done for 3-cables of the Kinoshita-Terasaka (K-T) and the Conway (C) knot by Morton, at the time [MT] was written. Some further account is given in [CM, MR], including a calculation using the quantum group (which is essentially equivalent to evaluating parts of the HOMFLY polynomial). This work yields different examples illustrating part (1) in Theorem 1.2 for the HOMFLY polynomial. These examples also address the 2-cable HOMFLY polynomial, by taking the companions to be 2-cables of mutants. A disadvantage of the way we collected our examples (see the beginning of §5) is that they pass by this case. Contrarily, we deal with the Kauffman polynomial, and with the double cover (which will be treated in the appendix). For the Kauffman polynomial mutant 3-satellite calculations might have been attempted, but despite some quest, we found no reliable record available.

A further example for the HOMFLY polynomial is provided in [DGST] (the knot in Figure 3.5 therein). Still it is worth noticing that the variance of the HOMFLY polynomial under a cabled or (2,0)-mutation was understood already from Morton’s (preceding) above explained work, as credited also in [CL]. Satellite knots (in opposition to links) deserve no particular prominence: by trivial skein theory standard cable polynomials are linear combinations of connected cable polynomials. Therefore, if former distinguish something, so must do (some of the) latter³. On the other hand, our Whitehead double pair from the proof of Proposition 3.2 is somewhat simpler than the knots in both [DGST] and [CM]. In [DGST] also similar examples for the Kauffman polynomial were expected. The related Question 1.6 therein can be answered (negatively, for the Kauffman polynomial), for instance, with the 2-cable distinction of 14_{41721} and 14_{42125} in Remark 3.4. After us, other pairs (distinguished by either 2-variable polynomials) were given in [MR2].

We will give later several further, more subtle, examples that relate also to the other mutant properties concerning 2-satellite polynomials. As far as only Question 3.1 is considered, one can also construct an infinite sequence of examples.

Let \mathcal{V}_k be the linear space of *Vassiliev knot invariants* of degree at most k and $\mathcal{X}_k = \mathcal{V}_k/\mathcal{V}_{k-1}$. The *degree* $d_v = \deg v$ of a Vassiliev invariant v is the smallest k with $v \in \mathcal{V}_k$.

Proof of Theorem 1.1. Figure 2 gives a ribbon presentation of the knots $K_1 = 14_{41721}$ and $K_2 = 14_{42125}$ as a pair of disks connected by a band. We add an equal number n of full-twists in the bands, and call the resulting knots $K_{1,n}$ and $K_{2,n}$.

The proof that the CJP coincides on $K_{1,n}$ and $K_{2,n}$ is essentially the same as for $K_1 = K_{1,0}$ and $K_2 = K_{2,0}$, only the half-twist coefficients of [MV] enter additionally into the formula.

The property that almost all knots $K_{p,n}$ are simple knots is established most easily using Thurston’s hyperbolic surgery theorem (see for example [Th, Th2]). This theorem implies that all but finitely many

³This is something very different from distinguishing whether the companion is a knot or link!

of the knots will be hyperbolic (and that when $n \rightarrow \infty$, the hyperbolic volumes will converge to the volume of the limit link, which is ≈ 10.99).

The distinction of $K_{1,n}$ and $K_{2,n}$ using the Whitehead double skein polynomial can be proved as follows.

Since we will need them several times below in this paper, let us first briefly review how to obtain Vassiliev invariants from the skein polynomial of a knot K . These Vassiliev invariants can be given by

$$(5) \quad P_{i,j}(K) := \sqrt{-1}^{i+j} \frac{d^j}{dl^j} \Big|_{l=\sqrt{-1}} [P(K)]_{m^i}$$

(where $i, j \geq 0$ and i is even, and $[P]_{m^i}$ is the coefficient of m^i in P). This is an invariant of degree $\deg P_{i,j} \leq i + j$ of K . (In fact, by work of Le and Murakami [LMu], the degree is exactly $i + j$.)

Let $W_+(K)$ be the untwisted (0-framed) Whitehead double of K with positive clasp. The dualization of this operation preserves the filtration of Vassiliev invariants. That is, if w is a Vassiliev invariant, then $v(K) := w(W_+(K))$ is also one, and

$$(6) \quad \deg v \leq \deg w.$$

Since the Whitehead double polynomial distinguishes our particular pair $(K_{1,n}, K_{2,n})$ for $n = 0$, there is a Vassiliev invariant $v(K) = P_{i,j}(W_+(K))$ of some degree

$$k = \deg v \leq \deg P_{i,j} \leq i + j,$$

contained in the Whitehead double skein polynomial, differing on K_1 and K_2 . (Note that the diagrams in figure 2 have writhe 0, so that the blackboard framed skein polynomial we calculated is the one of 0-framing. This coincidence is inessential, however: one can replace in the discussion W_+ by the Whitehead double for any fixed framing.) With the preceding explanation, one calculates from Table 1 that one can take e.g. $i = 2$ and $j = 9$, and so $k \leq 11$ is sufficient.

Now, a Vassiliev invariant v is known, from work initiated in [Tr] and then expanded in [St2], to behave polynomially in the number n of twists. That is, the map $n \mapsto v(K_{p,n})$ is a polynomial function in n , of degree at most $k = \deg v$, for $p = 1, 2$. These two polynomials are distinct, since their values differ for $n = 0$. Thus they will differ for all but at most k arguments n , that is, v will distinguish all but at most k of the pairs. Since v is determined by the Whitehead double HOMFLY polynomial, latter will differ too, and thus the pairs are not mutants. \square

Remark 3.9. An easy skein argument shows that the HOMFLY and Kauffman polynomial coincide in all pairs. It will require a bit more labor to check this for the 2-cable HOMFLY polynomial (and we have not done so).

Remark 3.10. Using the multiplicativity of the CJP under connected sum, one can find for any number n a family of n distinct knots with equal CJP, which are not mutants or satellites thereof. These knots are obviously not simple. We will show in Theorem B.1 in the second appendix how to construct simple ones.

Remark 3.11. It is intuitively clear that coincidences of the CJP are rather sporadic. Thurston's results that the hyperbolic volumes of 3-manifolds form a well-ordered set and are finite-to-one invariants imply that only finitely many knots with no Seifert fibered pieces in the JSJ decomposition have the same Gromov norm. The Volume conjecture then implies that only finitely many such knots have the same CJP, and suggestively the same is true under dropping the mild restriction on the JSJ decomposition. Thus it seems quite unlikely that one can obtain an *infinite* family of knots with equal CJP.

Contrarily, we have no procedure to find all knots with a given CJP. It is known, though, that there are non-concordant mutants (see for example [KL]), so, like mutation, concordance alone will not suffice to relate knots with the same CJP (see Problem 3.6).

4. MIRROR IMAGES

Since in the tables of [HT] a knot K is considered equivalent to its *mirror image* (or *obverse*) $!K$, a careful detection of mutants entails also attention to chiral knots which are mutants to their obverses. An

example of a 16 crossing knot, given by Sakuma and Kanenobu, is quoted in [Ka]. No such knots occur up to 13 crossings, because the 2-cable HOMFLY polynomial distinguishes all chiral knots from their obverses, although for some knots the uncabled HOMFLY and Kauffman polynomial fail, most prominently 9_{42} , and also 10_{71} . Note that taking the mirror image replaces one of the variables in the HOMFLY, Kauffman or Colored Jones polynomial by its inverse. Polynomials that remain invariant under this interchange are called below *reciprocal* or *self-conjugate*.

For 14 crossings, the 2-cable HOMFLY polynomial fails distinguishing mirror images on 15 prime chiral knots on which the uncabled polynomials fail too. 13 of them are indeed found to be mutants to their obverses, because they are mutants to achiral knots. The other two knots are distinguished from their mirror images by the Whitehead double HOMFLY polynomials. These knots are 14_{3802} and 14_{29709} ; see figure 4.

 14_{3802}  14_{29709}

Figure 4

 S

Figure 5: The staple tangle

It is natural to ask how well the Colored Jones polynomial would distinguish mirror images of such difficult cases. So we considered the knots we did not find mutants to their obverses, but which have zero signature and self-conjugate uncabled polynomials. Note that the Kauffman polynomial determines for *knots* the 2-Colored Jones polynomial by a result of Yamada [Y] (see also [Ki]). So for knots with reciprocal uncabled polynomials, the 1- and 2-Colored Jones polynomials must be reciprocal too. We tried to determine the 3-colored polynomial using the KnotTheory' Mathematica Package initiated by Dror Bar-Natan [BN2] (and its Colored Jones polynomial facility co-written with S. Garoufalidis). We obtained the polynomial only for a handful of our 14 crossing knots (and no knots of more crossings).

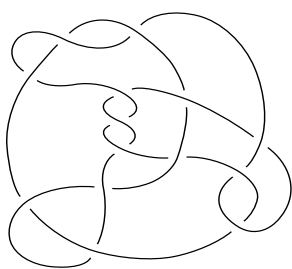
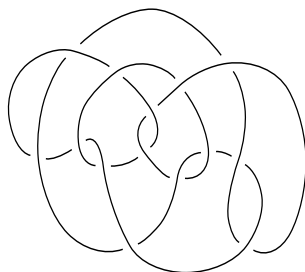
Example 4.1. Among others we calculated that the 3-Colored Jones polynomial distinguishes 14_{29709} and its mirror image. This polynomial is not reciprocal, thus providing the example for part (2) in Theorem 1.2:

$$J_{14_{29709}}(3; q) = 1/q^{31} - 2/q^{30} - 1/q^{29} + 8/q^{27} + 5/q^{26} - 18/q^{25} - 21/q^{24} + 16/q^{23} + 64/q^{22} + 3/q^{21} - 108/q^{20} - 76/q^{19} + 140/q^{18} + 194/q^{17} - 105/q^{16} - 353/q^{15} - 5/q^{14} + 483/q^{13} + 217/q^{12} - 569/q^{11} - 468/q^{10} + 560/q^9 + 734/q^8 - 480/q^7 - 957/q^6 + 346/q^5 + 1116/q^4 - 187/q^3 - 1208/q^2 + 24/q + 1240 + 132q - 1208q^2 - 290q^3 + 1119q^4 + 442q^5 - 967q^6 - 571q^7 + 754q^8 + 649q^9 - 493q^{10} - 661q^{11} + 240q^{12} + 575q^{13} - 17q^{14} - 437q^{15} - 110q^{16} + 262q^{17} + 158q^{18} - 121q^{19} - 129q^{20} + 24q^{21} + 82q^{22} + 9q^{23} - 31q^{24} - 17q^{25} + 8q^{26} + 9q^{27} - q^{28} - q^{29} - 2q^{30} + q^{31}.$$

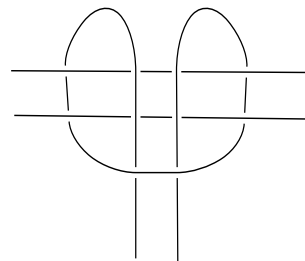
Similarly, the 3-colored polynomial distinguished the few other knots we could evaluate it on from their mirror images. Contrarily, we can prove now the following, which also settles part (3) (b) of Theorem 1.2.

Theorem 4.2. *There exist infinitely many hyperbolic knots K_n , such that K_n has the same CJP as its mirror image, but they are not mutants.*

Proof. Let S be the (3-string) staple tangle in figure 5. (The name is taken from [SW], where similar tangles are heavily used.) If one turns around one of the diagrams in Figure 2, one sees that the knots differ by a *staple turn*. This is a rotation of S by π around the axis vertical in the projection plane. It has the effect of mirroring the staple. The calculation for the proof of Proposition 3.3 shows that a staple turn does not change the CJP.

Now consider the knot K_n on the left in figure 6. The diagram contains a pretzel tangle $T_n = (-n, n)$ with n odd (we showed it for $n = 3$), and the remaining part consists of the join of two staple tangles S . For us it is useful here that mutation of T_n along the axis horizontal in the projection plane turns it into its mirror image. So K_n can be transformed into $!K_n$ by two turns of tangles S and one mutation (of T_n). Thus K_n and $!K_n$ have the same CJP. The limit link L_∞ , obtained by placing circles $N_{1,2}$ around each of the groups of n twists (and then be ignoring the twists by [Ad]), is a hyperbolic link (of volume ≈ 28.07). Then Thurston's hyperbolic surgery theorem assures that K_n are hyperbolic for large n .

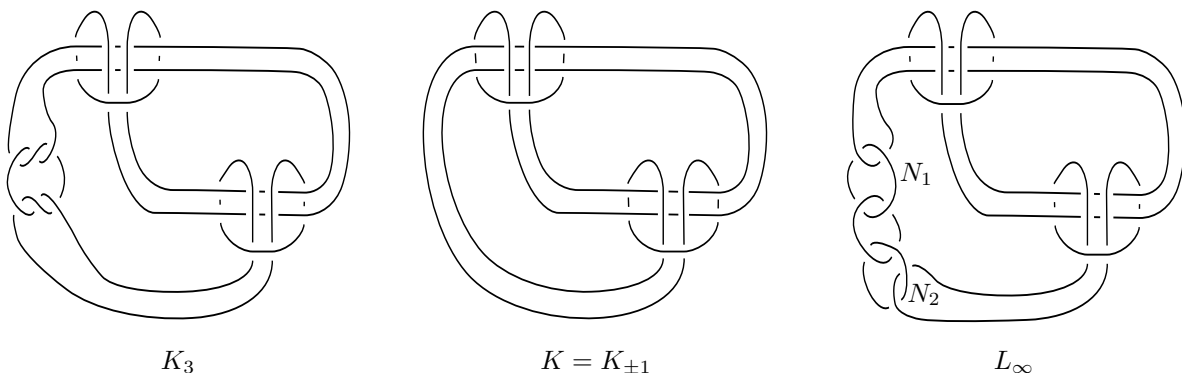

Figure 6

It remains to prove that K_n is not mutant to $!K_n$. Let L' be the 2-component trivial sublink of the limit link L_∞ , consisting of the two circles $N_{1,2}$. Then $\pm 1/m$ surgery along the components of L' performs at two occasions m full-twists inside the tangle T_n , turning it into T_{2m+n} . The work in [St2] then implies that for a Vassiliev invariant x , the function $n \mapsto x(K_n)$ is a polynomial function in n , of degree at most $d := \deg x$.

We will obtain a Vassiliev invariant x that suits our purpose using the HOMFLY polynomial. We follow the nomenclature in the proof of Proposition 3.2, and the convention (4). Calculation of the polynomial of the untwisted Whitehead double $W_+(K)$ of $K := K_{\pm 1}$ with positive clasp gives the m^2 -term

$$\begin{aligned} [P_{w_+}(K)]_{m^2}(l) &= -34l^{-14} + 181l^{-12} + 1535l^{-10} + 2803l^{-8} \\ &\quad - 1781l^{-6} - 15218l^{-4} - 28678l^{-2} - 29206 - 16406l^2 \\ &\quad - 2881l^4 + 2187l^6 + 1319l^8 + 137l^{10} - 38l^{12}. \end{aligned}$$

(Despite the 82 crossings of the diagram we have, this term takes only seconds to obtain if one uses the truncation algorithm described in [St9].) Now it is an easy skein calculation at the Whitehead double clasp that for $k > 0$ even,

$$(7) \quad [P_{w_+}(K)]_{m^k}(l) = [P_{w_+}(!K)]_{m^k}(l^{-1}) \cdot l^{-2}.$$

This shows that

$$[P_{w_+}(K)]_{m^2} - [P_{w_+}(!K)]_{m^2} = 4l^{-14}(1 - l^2)(l^2 + 1)^{12}.$$

Therefore by (5) there is a Vassiliev invariant x in P_{w_+} of degree d at most 14 with $x(K) \neq x(!K)$, and in fact, with the parity condition from [St4] we have $d \leq 13$. Thus x will distinguish from their mirror images all but at most 13 of the K_n . Since x is not changed under mutation, we see that K_n and $!K_n$ are not mutants. \square

Remark 4.3. It is known that mutation preserves the double branched cover $M_2(K)$ of a knot K , and this fact will become very important later. A main motivation for the construction of the examples here was to manifest the usefulness of polynomial and Vassiliev invariants as a tool to exclude mutation, in opposition to the study of $M_2(K)$. It is clear that $M_2(K) = M_2(!K)$, and since the peripheral system of K loses orientation in $M_2(K)$, there seems no way to prohibit a mutation between K and $!K$ by studying $\pi_1(M_2(K))$ (alone). The other type of invariants coming to mind are those derived from the Blanchfield pairing on the Alexander module (signatures and linking forms). But one easily comes across knots of trivial Alexander polynomial, where such methods will fail either. (See e.g. the knot K in figure 6.)

Example 4.4. The knot 14_{3802} in figure 4 is particularly interesting, because it is alternating. For alternating knots one can apply the strong geometric work in [MTh] and [Me]. Former result shows that 14_{3802} is chiral, and using the latter result one can easily deduce that 14_{3802} has no mutants, so in particular it cannot be a mutant to its mirror image. This conclusion is here especially difficult to obtain using the polynomials. We could not decide (computationally) whether 14_{3802} and its mirror image have the same Colored Jones polynomial (or even the same 3-Colored Jones polynomial).

Example 4.5. 14_{29709} and its mirror image provide an example of knots with the same 2-cable HOMFLY polynomials and the same volume, but different 3-Colored Jones polynomials. For knots of different volume, but equal 2-cable HOMFLY polynomials, we found previously the pair $(12_{341}, 12_{627})$ in [St3], and checked now similarly that the 3-Colored Jones polynomials are different. These examples show that the Colored Jones polynomial is not determined by the 2-cable HOMFLY polynomial.

In contrast, the following question remains open:

Question 4.6. Are there examples of knots with different (3-)colored Jones polynomial but equal Whitehead double HOMFLY (or Kauffman) polynomials?

In §3 we observed that the Colored Jones polynomial does not determine in turn even the uncabled HOMFLY polynomial.

Another interesting question raised by our verification is:

Question 4.7. Is every knot which is a mutant to its obverse actually a mutant to an achiral knot?

The above explanation implies that it is so up to 14 crossings. Similarly, there are 288 chiral prime knots of 16 crossings which the (uncabled) HOMFLY and Kauffman polynomials and the signature fail to separate from their mirror image. 117 are mutants to achiral 16 crossing knots, and all the other 171 are ruled out by the Whitehead double HOMFLY polynomials (though the 2-cable HOMFLY polynomials fail on 6 of them, all non-alternating). For 15 crossings all chiral prime knots are found distinguished from their obverses by one of the uncabled polynomials or the signature.

5. MORE DIFFICULT EXAMPLES

The pairs we presented came up in the first author's project to determine mutations among the low crossing knots tabulated in [HT]. Up to 13 crossings this task was completed by tracking down coincidences of Alexander, Jones polynomial and volume (up to a certain computable precision) on the one hand, and then exhibiting the mutation in minimal crossing diagrams on the other hand.

In contrast, a (non-complete) verification of 14 and 15 crossing knots exhibited several more difficult cases, discussed in [St]. For some pairs we had to seek non-minimal crossing diagrams to display the mutation. Others provided examples of the type we showed in §3. Here may be a proper place to stress that the match of the P , F and 2-cable P polynomials on all our examples is intentional. Beside a mutation status check, it served as a selector for good candidates with the same CJP. The proof to confirm equality of the CJP for each pair entails the quest for proper presentation of the knots, and so requires more effort than its length may let appear. We could therefore examine only a limited number of pairs. It is difficult also to exclude pairs, since a direct calculation of the 3-colored polynomial is feasible only in the fewest cases.

Among the remaining, most problematic, pairs is $(14_{41739}, 14_{42126})$, and a number of pairs of 15 crossing knots. An extensive (though not exhaustive) search of diagrams up to 18 crossings failed to show a mutation, but, along with all the invariants that do so for the previous pairs, we established (in the way explained before the proof of Proposition 3.2) that Whitehead double skein polynomials also coincide.

By a similar calculation to the proof of Proposition 3.3, we managed to verify for some pairs that the colored Jones polynomials are also equal. These pairs include the 14 crossing knots 14_{41739} and 14_{42126} in Figure 7.

Lemma 5.1. $J_{14_{41739}} = J_{14_{42126}}$

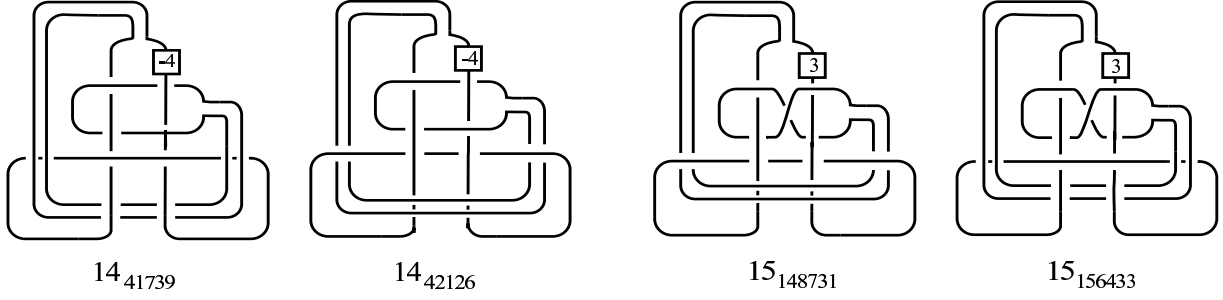

Figure 7

Figure 8

Proof. We use the diagrams in the figure (a box with an integer w inside means $|w|$ kinks of writhe $\text{sgn}(w)$). Setting

$$(8) \quad \Gamma(N, k_1, k_2) := \frac{\langle 2k_1 \rangle \langle 2k_2 \rangle \langle 2k_1 \rangle}{\langle N, N, 2k_1 \rangle \langle N, N, 2k_2 \rangle \langle 2k_1, 2k_2, 2k_1 \rangle},$$

we find

$$J_{14_{41739}}(A; N) = \sum_{k_1=0}^N \sum_{k_2=0}^N \Gamma(N, k_1, k_2) \times \left\langle \begin{array}{c} N \\ \text{Diagram 1} \\ 2k_1 \end{array} \right\rangle \left\langle \begin{array}{c} 2k_1 \\ \text{Diagram 2} \\ 2k_2 \end{array} \right\rangle,$$

$$J_{14_{42126}}(A; N) = \sum_{k_1=0}^N \sum_{k_2=0}^N \Gamma(N, k_1, k_2) \times \left\langle \begin{array}{c} N \\ \text{Diagram 3} \\ 2k_1 \end{array} \right\rangle \left\langle \begin{array}{c} 2k_1 \\ \text{Diagram 4} \\ 2k_2 \end{array} \right\rangle,$$

(again with the sums restricted over k_1, k_2 for which the denominator of $\Gamma(N, k_1, k_2)$ makes sense). Comparison shows again $J_{14_{41739}}(A; N) = J_{14_{42126}}(A; N)$. \square

The CJP of the pair of (slice, trivial Alexander polynomial) knots in Figure 8 is found equal from the displayed diagrams, in a similar way to 14_{41739} and 14_{42126} .

A third pair is provided by the knots 15_{219244} and 15_{228905} in figure 9.

Lemma 5.2. $J_{15_{219244}} = J_{15_{228905}}$

Proof. With $\Gamma(N, k_1, k_2)$ as in (8), we have from figure 9

$$J_{15_{219244}}(A; N) = \sum_{k_1=0}^N \sum_{k_2=0}^N \Gamma(N, k_1, k_2) \times \left\langle \begin{array}{c} N \\ \text{Diagram 5} \\ 2k_2 \end{array} \right\rangle \left\langle \begin{array}{c} 2k_1 \\ \text{Diagram 6} \\ -5 \end{array} \right\rangle,$$

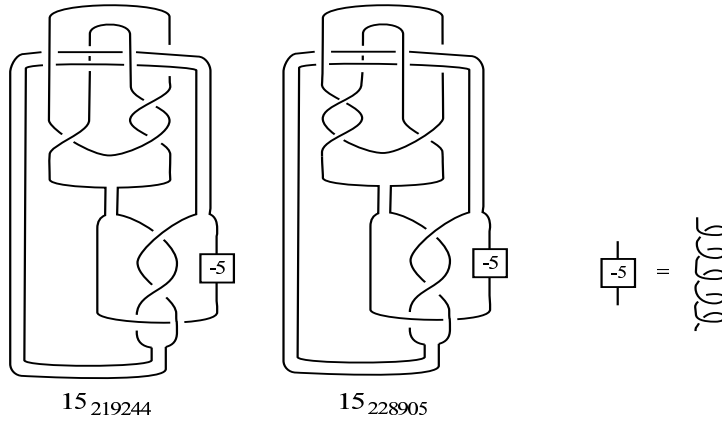

Figure 9

$$J_{15_{228905}}(A; N) = \sum_{k_1=0}^N \sum_{k_2=0}^N \Gamma(N, k_1, k_2) \times \left\langle \begin{array}{c} N \\ \text{Diagram 1} \\ 2k_1 \\ 2k_2 \end{array} \right\rangle \left\langle \begin{array}{c} 2k_1 \\ \text{Diagram 2} \\ 2k_2 \\ -5 \\ N \end{array} \right\rangle . \quad \square$$

One more pair is (15₂₂₀₅₀₄, 15₂₃₄₈₇₃) in figure 10.

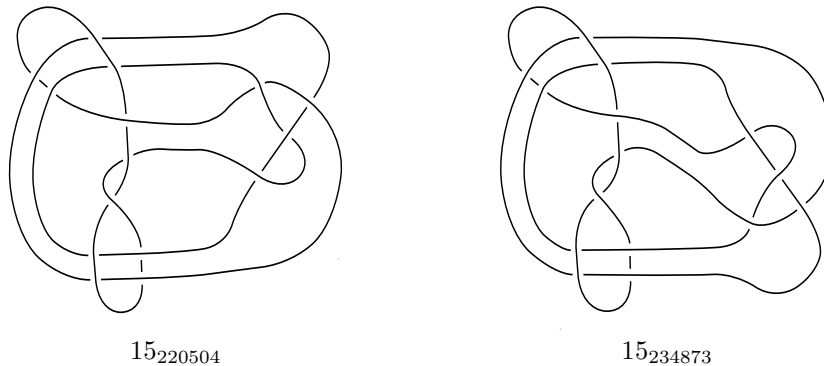

Figure 10

The last two pairs shown are different from the previous two also in the point that we do not know if they are concordant or not (see Problem 3.6).

In an attempt to exclude mutation, we relied on the fact that mutants have the same double branched covers. We consulted Daniel Matei, who succeeded in distinguishing these pairs (and also the few others he tried, with differing degree of effort) by the representations of the fundamental group of the cover. In an appendix of the paper he gives some details about his calculation.

The complexity of the 2-cable Kauffman polynomial makes its evaluation very difficult. It is certainly not to be considered a reasonable mutation criterion. We tried evaluating it on some pairs (as in Remark 3.4), mainly driven by curiosity if it would distinguish pairs left undistinguished by the HOMFLY polynomials. We succeeded to determine the polynomial only for two of the 15 crossing pairs with equal Whitehead double skein polynomial. The 2-cable Kauffman polynomials, too, failed to distinguish the knots.

Example 5.3. One of these two pairs is (15₁₄₈₇₃₁, 15₁₅₆₄₃₃) of Figure 8. For this pair we were able to calculate (and found to be equal) connected 2-cable Kauffman polynomials for both mirror images,

and thus we know that these two knots satisfy *all* polynomial coincidence properties known for mutants (those summarized in the introduction). The apparent lack of diagrams exhibiting the mutation deepened the decision problem whether the knots are mutants or not. Daniel Matei's subsequent exclusion result thus leads to the most striking among the examples we have, showing complete failure of the polynomial invariants to determine the mutation status (see part (3) (a) in Theorem 1.2). On the other hand, with Theorem 4.2 we saw examples, where the polynomial invariants seem indispensable (see Remark 4.3). This underscores the significance of both approaches.

Remark 5.4. Although $\pi_1(M_2(K))$ becomes a major distinction tool, we know of no pair in which its abelianizations $H_1(M_2(K))$ are different. This relates to a question of Rong [Kr, problem 1.91(4b)], whether J_K would always determine $H_1(M_2(K))$. This question can be seen, together with the aforementioned relation of CJP to the Alexander polynomial and the signature function, as part of a larger conception whether the CJP might determine the Seifert matrix (up to S -equivalence). For some related motivation see the remark after problem 1.87 in [Kr].

Acknowledgement. The first author was supported by Postdoc grant P04300 of the Japan Society for the Promotion of Science (JSPS). He would wish to thank his host Prof. T. Kohno, and also H. Morton, D. Ruberman, P. Traczyk and the referee for some helpful remarks. The second author's research was supported by the 21st century COE program at the Graduate School of Mathematical Sciences, the University of Tokyo and Osaka City University. He would like to thank Prof. A. Kawauchi and Prof. T. Kohno for helpful suggestions.

APPENDIX A. FUNDAMENTAL GROUP CALCULATIONS (BY DANIEL MATEI)

If K is a knot, we denote by $M_2(K)$ the 2-fold cover of the 3-sphere branched along K . It is well-known (e.g. [Si, Vi]), that the homeomorphism type of the closed 3-manifold $M_2(K)$ is a mutation invariant. Here we are mainly interested in its fundamental group $\pi(K) := \pi_1(M_2(K))$. Let us review how a presentation of $\pi(K)$ can be obtained from the knot group $G(K)$.

The fundamental group $H(K)$ of the 2-fold unbranched cover of the knot complement is the subgroup of $G(K)$ defined by the kernel of the homomorphism $G(K) \rightarrow \mathbb{Z}_2$ sending a meridian $\mu \in G(K)$ of K (and in fact all meridians) to the generator of \mathbb{Z}_2 . Then $\pi(K)$ is the quotient $H(K)/(\mu^2)$ of $H(K)$ by the subgroup normally generated by the squares of the meridians of K , see [Ro] for example. For our purposes it is more convenient to view $\pi(K)$ as the index 2 subgroup of $G(K)/(\mu^2)$ determined by the descending homomorphism $G(K)/(\mu^2) \rightarrow \mathbb{Z}_2$.

The n -strand *braid group* B_n is considered generated by the Artin *standard generators* σ_i for $i = 1, \dots, n-1$. These are subject to relations of the type $[\sigma_i, \sigma_j] = 1$ for $|i-j| > 1$, and $\sigma_{i+1}\sigma_i\sigma_{i+1} = \sigma_i\sigma_{i+1}\sigma_i$. By a theorem of Alexander, every knot or link K is the *closure* of a braid b . We call such a b a *braid presentation* (or *braid description*) of K .

Suppose K is given as the closure of the n -strand braid b , written as a product in the standard generators $\sigma_k, 1 \leq k < n$, and their inverses. We view braids as automorphisms of the free group on generators x_1, \dots, x_n , so that $\sigma_k(x_i)$ is equal to $x_k x_{k+1} x_k^{-1}$ if $i = k$, to x_k if $i = k+1$, and to x_i otherwise.

We use the program GAP [G], and input braid generators and braids as automorphisms of the free group. We illustrate this on an example braid $b_1 = \sigma_1 \sigma_2^2 \sigma_3^{-1} \dots \in B_4$ like:

```
gap>f:=FreeGroup(4);
gap>s1:=GroupHomomorphismByImages(f,f,[f.1,f.2,f.3,f.4],[f.1*f.2*f.1^-1,f.1,f.3,f.4]);
...
gap>b1:=s1*s2*s2*s3^-1*...
```

The knot group $G(K)$ has then a presentation with meridian generators x_i and relations $b(x_i) = x_i$, where $1 \leq i \leq n$. A presentation for $G(K)/(\mu^2)$ is obtained simply by adding $\mu^2 = 1$ to the above relations, with $\mu = x_i$ for some i .

```
gap>rels:=List([1..4],i->Image(b1,GeneratorsOfGroup(f)[i])*GeneratorsOfGroup(f)[i]^-1);
gap>rels:=Concatenation(rels,[GeneratorsOfGroup(f)[1]^2]);
```



```
gap>q1:=f/rels;
```

From this presentation of $G(K)/(\mu^2)$, GAP then computes a presentation for $\pi(K)$. First \mathbb{Z}_2 is realized as a symmetric group of size 2 and the homomorphism $G(K)/(\mu^2) \rightarrow \mathbb{Z}_2$ is defined on generators by $x_i \rightarrow (1, 2)$ for all i , using the command `GroupHomomorphismByImages`. Then its kernel $\pi(K)$ is found and converted into a finitely presented group.

```
gap>c2:=Group((1,2));
gap>p1:=Kernel(GroupHomomorphismByImages(q1,c2,GeneratorsOfGroup(q1),[(1,2),(1,2),(1,2),(1,2)]));
gap>p1:=Image(IsomorphismFpGroup(p1));
```

Finally a presentation is created and displayed for the fundamental group of the branched cover. For example, from the braid word in table 2 for 14_{41763} we obtain (the computer output is indicated by italics):

```
gap>TzPrint(PresentationFpGroup(p1));
#I generators: [ F1, F2, F3 ]
#I relators:
#I 1. 11 [ 2, -3, 1, 3, -2, -2, 3, 1, -3, 2, -1 ]
#I 2. 12 [ 1, -2, 1, -2, 3, -1, 3, -2, 1, -2, 1, 2 ]
#I 3. 20 [ -3, 2, 2, -3, -3, 2, 2, -3, 2, 2, -3, -3, 2, 2, -3, 2, 1, -2, 1, 2 ]
```

For a pair of knots K_1, K_2 we will distinguish their double branched cover groups $\pi(K_1)$ and $\pi(K_2)$ using two types of numerical invariants. Denote by π either one of the two groups. The first invariant is simply the number of epimorphisms $\delta_\Gamma(\pi)$ of π onto a finite group Γ up to automorphisms of the target. The list of such epimorphisms is determined via the GAP command `GQuotients(pi, Gamma)`. The second invariant is a list of abelianizations of certain finite index subgroups of π . The list is of two types: either a list $Ab_r(\pi)$ of the abelianizations of all (conjugacy classes of) index r subgroups of π , or a list $Ab_\Gamma(\pi)$ of the abelianizations of the (conjugacy classes of) kernels of all epimorphisms from π onto Γ . The finite index subgroups are determined via the GAP command `LowIndexSubgroupsFpGroup(pi, TrivialSubgroup(pi), index)`. The kernels are obtained applying the command `Kernel` to the homomorphisms in `GQuotients(pi, Gamma)`. Finally, the abelianizations are obtained using the command `AbelianInvariants`, and they are presented as lists of integers. For example, `[0, 0, 2, 3, 3, 4]` stands for $\mathbb{Z} \times \mathbb{Z} \times \mathbb{Z}_2 \times \mathbb{Z}_3 \times \mathbb{Z}_3 \times \mathbb{Z}_4$.

As an example, let us verify that the first homology group of $\pi(14_{41763})$ is what its order $\Delta_{14_{41763}}(-1)$, determined by the Alexander polynomial Δ , implies that it should be:

```
gap>AbelianInvariants(p1);
[ 3 ]
```

We start with three pairs (K_1, K_2) of knots, whose groups $\pi(K_1)$ and $\pi(K_2)$ are not isomorphic, as their $\delta_\Gamma(\pi)$ are different:

- for $(14_{41763}, 14_{42021})$ we have $\delta_\Gamma(\pi_1) = 2$ and $\delta_\Gamma(\pi_2) = 0$ with $\Gamma = Alt(7)$.

```
gap>Length(GQuotients(pi1, AlternatingGroup(7)));
2
gap>Length(GQuotients(pi2, AlternatingGroup(7)));
0
```
- for $(15_{219244}, 15_{228905})$ we have $\delta_\Gamma(\pi_1) = 1$ and $\delta_\Gamma(\pi_2) = 0$ with $\Gamma = PSL(2, 13)$.
- for $(15_{220504}, 15_{234873})$ we have $\delta_\Gamma(\pi_1) = 2$ and $\delta_\Gamma(\pi_2) = 1$ with $\Gamma = PSL(2, 7)$.

For the next three pairs we could not find (small enough) finite groups Γ for which GAP returned (in a reasonable amount of time) different values of $\delta_\Gamma(\pi)$. We turned then to the abelianizations of finite index subgroups mentioned above.

For the pair $(14_{41739}, 14_{42126})$ it was possible to distinguish $\pi(K_1)$ from $\pi(K_2)$ by considering the abelianizations of the index 6 subgroups.

```
gap>lis:=LowIndexSubgroupsFpGroup(pi1, TrivialSubgroup(pi1), 6);
gap>lis6:=Filtered(lis, H->Index(pi1, H)=6);
```

The second command is needed to select the subgroups of index = 6; the first command `LowIndexSubgroupsFpGroup` gives subgroups up to given index. This feature depends on the algorithm GAP uses to find the quotients, and is feasible only for subgroups of very small index.

Each group has 3 index 6 subgroups, but the abelianizations of one of them on either side differ:

```
gap>Length(lis6);
3
gap>List(lis6,H->AbelianInvariantsSubgroupFpGroup( pi1, H ));
[ [ 9, 9 ], [ 3, 5, 9 ], [ 2, 2, 16 ] ]
...
gap>List(lis6,H->AbelianInvariantsSubgroupFpGroup( pi2, H ));
[ [ 0, 4, 9 ], [ 3, 5, 9 ], [ 2, 2, 16 ] ]
```

For the next two pairs GAP could not determine enough low index subgroups of $\pi(K_1)$ and $\pi(K_2)$ in a reasonable amount of time. We then considered normal subgroups of higher index and computed their abelianizations.

For the pair $(14_{41721}, 14_{42125})$ we first determined that $\delta_\Gamma(\pi_1) = \delta_\Gamma(\pi_2) = 1$ with $\Gamma = PSL(2, 7)$.

```
gap>p1s127:=GQuotients(p1,PSL(2,7));
[ [ F1, F2, F3 ] -> [ (1,4)(2,5)(3,8)(6,7), (1,3,6,7)(2,4,5,8), (1,2,3,5)(4,8,7,6) ] ]
gap>p2s127:=GQuotients(p2,PSL(2,7));
[ [ F1, F2, F3, F4 ] -> [ (2,7,3,8,5,6,4), (1,2,4,7,3,5,8), (2,6,8,7,4,5,3), (2,3,5,4,7,8,6) ] ]
```

The two epimorphisms $h_1 : \pi_1 \rightarrow \Gamma$, respectively $h_2 : \pi_2 \rightarrow \Gamma$ are given by the images of the generators of π_i , treating $\Gamma = PSL(2, 7)$ as a subgroup of S_8 and specifying the cycle decomposition of the permutations.

Then we computed using `AbelianInvariants(Kernel(p1s127[1]))`; and `AbelianInvariants(Kernel(p2s127[1]))`; the abelianizations A_1 and A_2 of the kernels of $h_{1,2}$. Since A_1 has 3-torsion, whereas A_2 does not, we may conclude that $\pi(K_1)$ and $\pi(K_2)$ are not isomorphic.

Similarly, for the pair $(15_{148731}, 15_{156433})$ we first determined that $\delta_\Gamma(\pi_1) = \delta_\Gamma(\pi_2) = 1$ with $\Gamma = Alt(6)$. Then we found that the abelianizations A_1 and A_2 of the kernels of the two epimorphisms onto $Alt(6)$ are distinct, as A_1 is entirely torsion, whereas A_2 has free part of rank 10. Thus $\pi(K_1)$ and $\pi(K_2)$ are not isomorphic. This last pair was the most difficult to break. The subgroups have a rather large index, 360, the order of $Alt(6)$, and their abelianizations are fairly complicated.

Table 2 summarizes the results for the 6 explicit pairs we treated. They consist of the 2 pairs of §3 (Figures 2 and 3; where the Whitehead double skein polynomial can also be used to exclude mutation), and the 4 pairs of §5 (Figures 7, 8, 9, 10; where the use of $\pi(K)$ is essential).

Daniel Matei, Institute of Mathematics "Simion Stoilow" of the Romanian Academy P.O. BOX 1-764, RO-014700 Bucharest, Romania; daniel.matei@imar.ro

and

Graduate School of Mathematical Sciences, University of Tokyo, 3-8-1 Komaba Meguro-ku, Tokyo 153-8914, Japan

APPENDIX B. AN EXTENSION OF THE MAIN RESULT (BY THE FIRST AUTHOR)

In this appendix we extend Theorem 1.1 in the following way:

Theorem B.1. *For any number n , there exists a family of n distinct hyperbolic knots with equal CJP, which are not mutants.*

We noted in Remark 3.11 that by Thurston's work such an *infinite* family would contradict the Volume conjecture. Thus, regarding size at least, our statement is probably the maximal possible.

Table 2: The data for the 6 pairs: knots, braid presentation, number of generators and relations in the found presentation of π , and distinction method. The generators are numbered f_1, \dots, f_n ; in the relations we write i for f_i and use $\delta_i = f_i f_{i+1}^{-1} f_i$ and $\gamma_i = f_i f_{i-1}^{-1} f_i$ to shorten the words. The abelianizations are abbreviated by omitting the product signs between the cyclic groups and writing \mathbb{Z}_*^k for (the product of) k copies of \mathbb{Z}_* .

pair	braids	# gen of π	relators	distinction
1441721	$\sigma_1^{-1} \sigma_2 \sigma_3 \sigma_4^{-1} \sigma_5^{-1} \sigma_6^{-1} \sigma_5 \sigma_4^{-1} \sigma_3^{-1} \sigma_2^{-1} \sigma_4$ $\sigma_1 \sigma_3 \sigma_2 \sigma_4^{-1} \sigma_3 \sigma_4 \sigma_5^{-1} \sigma_4 \sigma_3^{-1} \sigma_2^{-1} \sigma_6 \sigma_5^{-1}$ $\sigma_4^{-1} \sigma_3^{-1} \sigma_4 \sigma_5 \sigma_4^{-1} \sigma_5 \sigma_4$	3	$[3 1^{-2} \delta_2 1^{-2} 2 \delta_1 2^{-1} 1 2 1^{-2} \delta_2 1^{-2}]; [3^{-1} 2 1^{-1} \delta_1^{-1} 2 1^{-1} \delta_1^{-1} 2 1^{-2} \delta_1^{-1} 2$ $1^{-1} \delta_1^{-1} 2 1^{-2} \delta_2 1^{-2} 2]; [3 2^{-1} 1 \delta_1 2^{-1} 1 \delta_1 2^{-1} 1^2 2^{-1} 3 1^{-2} \delta_2 1^{-1} \delta_1^{-1} 2 \delta_1^{-1}$ $1^{-1} \delta_2 1^{-2}]; [\delta_1^2 2^{-1} 1^2 \delta_2^{-1} 3 2^{-1} 1 \delta_1 2^{-1} 1 \delta_1 2^{-1} 1 \delta_1 1 \delta_2^{-1} 1 \delta_1 1 2^{-1}]$	$Ab_{PSL(2,7)} = [\mathbb{Z}_2 \mathbb{Z}_3^{15} \mathbb{Z}_5^{19} \mathbb{Z}_7^3$ $\mathbb{Z}_{11}^8]$
1442125	$\sigma_1^{-1} \sigma_2 \sigma_3 \sigma_4 \sigma_5^{-1} \sigma_6^{-1} \sigma_5 \sigma_4 \sigma_3^{-1} \sigma_2^{-1} \sigma_4^{-1} \sigma_1$ $\sigma_3 \sigma_2 \sigma_4 \sigma_3 \sigma_4^{-1} \sigma_5^{-1} \sigma_4^{-1} \sigma_3^{-1} \sigma_2^{-1} \sigma_6 \sigma_4 \sigma_5^{-1}$ $\sigma_4 \sigma_3^{-1} \sigma_4^{-1} \sigma_5^2 \sigma_4^{-1}$	4	$[1^{-1} 2 4^{-1} 2 4^{-1} 2 1^{-1}]; [\delta_3^{-1} 2^2 1^{-1} 4 2^{-1} 1 \delta_2^{-1} 1 2^{-1} 4]; [1 \delta_2 1 2^{-1} 4^2 2^{-1} 1$ $\delta_2 1^{-1} 2 4^{-1} 1^{-1} 2 4^{-1}]; [4 2^{-1} 1 \delta_2^{-1} 1^{-1} 2 4^{-1} 2^{-1} 4 3^{-1} 2 4 2^{-1} 1 \delta_2^{-1} 1^{-1} 2$ $4^{-1} 2^{-1} 3 4^{-1} 2 1^{-1} \delta_2]$	$Ab_{PSL(2,7)} = [\mathbb{Z}_2 \mathbb{Z}_7^3 \mathbb{Z}_7^7 \mathbb{Z}_9^6]$]
1441763	$\sigma_1^{-1} \sigma_2^{-1} \sigma_3^{-1} \sigma_4 \sigma_3^{-1} \sigma_4 \sigma_2^{-1} \sigma_4 \sigma_1 \sigma_3^{-1} \sigma_2$ $\sigma_3^{-1} \sigma_4 \sigma_3^2 \sigma_2$	3	$[2 3^{-1} 1 3 2^{-2} 3 1 3^{-1} 2 1^{-1}]; [\delta_1 2^{-1} 3 1^{-1} 3 2^{-1} \delta_1 2]; [3^{-1} 2^2 3^{-2} 2 \delta_2 2 3^{-2}$ $2 \delta_2 \delta_1 2]$	$\delta_{Alt(7)} = 2$
1442021	$\sigma_1^{-1} \sigma_2 \sigma_1^{-1} \sigma_2 \sigma_3 \sigma_4 \sigma_3^{-1} \sigma_2^{-2} \sigma_1^{-1} \sigma_2 \sigma_1^{-1}$ $\sigma_3^{-1} \sigma_2 \sigma_4^{-1} \sigma_3$	3	$[1^{-1} \gamma_3^{-1} 1^{-1} \delta_1^{-1} 2 1^{-1}]; [1^{-2} 2 3^{-1} \delta_1 1 \delta_1 3^{-1} 2 1^{-2} 3]; [1 2^{-1} 3 \delta_1^{-1} \gamma_3^2 \delta_1^{-1}$ $\gamma_3^2 \delta_1^{-1} 3 2^{-1} 1]$	$\delta_{Alt(7)} = 0$
1441739	$\sigma_1^{-1} \sigma_2 \sigma_3 \sigma_4^{-1} \sigma_5^{-1} \sigma_6^{-1} \sigma_5 \sigma_4^{-1} \sigma_3^{-1} \sigma_2^{-1} \sigma_4$ $\sigma_1 \sigma_3 \sigma_2 \sigma_4^{-1} \sigma_3 \sigma_4 \sigma_5^{-1} \sigma_4 \sigma_3^{-1} \sigma_2^{-1} \sigma_6 \sigma_5^{-1}$ $\sigma_4^{-1} \sigma_3^{-1} \sigma_4 \sigma_5^{-2} \sigma_4 \sigma_5^{-1}$	3	$[3^{-1} 2 \delta_1 2^{-1} 1 \delta_2 3^{-1} 2 1^{-1} \delta_2 3^{-1} 2 \delta_1 2^{-1} 1 2 3^{-1} 1^2]; [\delta_1^{-1} 2 1^{-1} \delta_1^{-2} 2 1^{-1}$ $\delta_2^{-1} 3 2^{-1} \delta_1^{-1} 2 1^{-1} \delta_2^{-1} \delta_1^{-1} 2 1^{-1} \delta_2^{-1} 3 2^{-1}]; [2 1^{-2} \delta_2 3^{-1} 2 \delta_1 2^{-1} 1 \delta_2 3^{-1}$ $2 1^{-2} 2 \delta_1 2^{-1} 1 \delta_2 3^{-1} 2 \delta_1 2^{-1} 1]$	$Ab_6 = [[\mathbb{Z}_9^2], [\mathbb{Z}_3 \mathbb{Z}_5 \mathbb{Z}_9], [\mathbb{Z}_2^2$ $\mathbb{Z}_{16}]]$
1442126	$\sigma_1^{-1} \sigma_2 \sigma_3 \sigma_4 \sigma_5^{-1} \sigma_6^{-1} \sigma_5 \sigma_4 \sigma_3^{-1} \sigma_2^{-1} \sigma_4^{-1} \sigma_1$ $\sigma_3 \sigma_2 \sigma_4 \sigma_3 \sigma_4^{-1} \sigma_5^{-1} \sigma_4^{-1} \sigma_3^{-1} \sigma_2^{-1} \sigma_6 \sigma_4 \sigma_5^{-1}$ $\sigma_4 \sigma_3^{-1} \sigma_4^{-1} \sigma_5^{-2} \sigma_4^{-1}$	3	$[1 \delta_2^{-1} 1^2 \delta_2^{-1} 1^4 \delta_2^{-1} 1^2 \delta_2^{-1} 1 3 1^{-1} 3]; [3 2^{-1} 1 3 1^{-1} 3 2^{-1} 1^{-1} \delta_2 1^{-2} \delta_2 1^{-1}$ $2^{-1} 3 1^{-1} 3 1 \delta_2^{-1} 1 \delta_1 1 2^{-1}]; [1^{-2} 3 2^{-1} 1^{-1} \delta_2 1^{-2} \delta_2 1^{-1} 2^{-1} 1^{-1} \delta_2 1^{-2} \delta_2$ $1^{-1} 2^{-1} 3 1^{-2} \delta_2]$	$Ab_6 = [[\mathbb{Z} \mathbb{Z}_4 \mathbb{Z}_9], [\mathbb{Z}_3 \mathbb{Z}_5 \mathbb{Z}_9$], $[\mathbb{Z}_2^2 \mathbb{Z}_{16}]]$
15148731	$\sigma_1^{-1} \sigma_2^{-1} \sigma_3^{-1} \sigma_4^2 \sigma_5^{-1} \sigma_4 \sigma_3^{-1} \sigma_2 \sigma_1 \sigma_3 \sigma_4 \sigma_3$ $\sigma_2 \sigma_3 \sigma_4^{-2} \sigma_5 \sigma_4^{-1} \sigma_3 \sigma_2^{-1} \sigma_4^{-1} \sigma_3$	3	$[2^2 \delta_1 2^2 3^2]; [1^{-1} 2 3 1 3^{-1} 2^{-2} 3^{-1} 1 3 2]; [2^{-1} 3^{-1} 1^{-1} 3^{-1} 2^{-1} \delta_1 3^{-1} \delta_1$ $2^{-1} 3^{-1} 1^{-1} 3^{-1} 2^{-2}]$	$Ab_{Alt(6)} = [\mathbb{Z}_2^4 \mathbb{Z}_3^{17} \mathbb{Z}_4^{60}$ $\mathbb{Z}_5^{10} \mathbb{Z}_9^7 \mathbb{Z}_{19}^3]$
15156433	$\sigma_1^{-1} \sigma_2^{-1} \sigma_3^{-1} \sigma_4 \sigma_5 \sigma_3^{-1} \sigma_2^2 \sigma_3^{-1} \sigma_4^{-1} \sigma_3 \sigma_2^{-1}$ $\sigma_1 \sigma_2^{-2} \sigma_3 \sigma_4 \sigma_3^{-1} \sigma_5^{-1} \sigma_4^{-1} \sigma_2 \sigma_3^{-1} \sigma_2$	4	$[\delta_1^{-1} \delta_3 4 3^{-1} \delta_1 3^{-1} \delta_1 3^{-1} 4 \delta_3 1^{-1} 2]; [4 3^{-1} \delta_1 3^{-1} \delta_1 \delta_3^{-1} 4 3^{-1} \delta_1 2^{-1} 1 \delta_3^{-1}$ $1]; [\delta_1 3^{-1} 2 \delta_3^{-1} \delta_1 2^{-1} 1 \delta_3^{-2} \delta_1 2 1^{-1} \delta_3 1^{-1} 2 3^{-1} \delta_1 \delta_3^{-1}]; [2 \delta_3^{-1} \delta_1 2^{-1} 1$ $\delta_3^{-2} \delta_1 4^{-1} 3 \delta_1^{-1} 3 2^{-1} 1 \delta_3^{-1} 1 2^{-1} 4^{-1} 3 \delta_1^{-1} 3 2^{-1} 1 \delta_3^{-1} 1]$	$Ab_{Alt(6)} = [\mathbb{Z}^{10} \mathbb{Z}_2^{17} \mathbb{Z}_3^{21} \mathbb{Z}_5^{10}$ $\mathbb{Z}_8^6 \mathbb{Z}_{16} \mathbb{Z}_{17}^5 \mathbb{Z}_{32}^4 \mathbb{Z}_{64}^4]$
15219244	$\sigma_1 \sigma_2^2 \sigma_3^{-1} \sigma_1 \sigma_2^{-1} \sigma_1^2 \sigma_2^2 \sigma_3^{-1} \sigma_2 \sigma_1 \sigma_2^{-1} \sigma_3^{-1}$	3	$[\gamma_3 3 \delta_2^{-1} 1 \delta_1 1 2^{-1}]; [1^{-1} \delta_1^{-1} 2 1^{-2} 2 3 1^{-1} 3 \gamma_3 3 1^{-1} 3 2]; [2^{-1} 1^2 2^{-1} 1^{-1}$ $\delta_2 1^{-1} 2^{-1} 1^2 2^{-1} 1^{-1} \delta_2 1^{-1} 2^{-1} 1^2 2^{-1} 3^{-1}]$	$\delta_{PSL(2,13)} = 1$
15228905	$\sigma_1 \sigma_2^{-1} \sigma_3^{-1} \sigma_1 \sigma_2^2 \sigma_3^{-1} \sigma_1^2 \sigma_2 \sigma_1^{-1} \sigma_2 \sigma_3^{-1} \sigma_2$ σ_1	3	$[3^2 2 3 2 1^{-1} 2 3 2 3^2 1^{-2}]; [2 1^{-3} 2 3^{-1} 1^3 2^{-1} 3^{-1} 2^{-1} 3^{-1} 2^{-1} 1^3 3^{-1}]; [1^3$ $2^{-1} 3 1^{-2} 3^2 1^{-2} 3 2^{-1} 1^3 \delta_2^{-1}]$	$\delta_{PSL(2,13)} = 0$
15220504	$\sigma_1^{-1} \sigma_2 \sigma_3^{-1} \sigma_4 \sigma_5 \sigma_2 \sigma_3^2 \sigma_2 \sigma_1 \sigma_2^2 \sigma_3^{-1} \sigma_4^{-1} \sigma_2$ $\sigma_3^{-1} \sigma_2 \sigma_3^{-1} \sigma_4^{-1} \sigma_5^{-1} \sigma_4^{-1} \sigma_3 \sigma_2$	4	$[3 1^{-1} \delta_1^{-1} 1^{-1} \delta_1^{-1} 1^{-1} 3]; [4^{-1} 1^3 4^{-1} 1^3 4^{-1} 3 4^{-1} 3^{-1} 4^{-1} 3]; [4^{-1} 3^{-1} 1 \delta_1$ $4 1^{-3} 4 \delta_1 1 3^{-1}]; [3 4 3^{-1} 4 3^2 1^{-2} 2^2 1^{-2} 3^2 1 2 1^{-2} 3]$	$\delta_{PSL(2,7)} = 2$
15234873	$\sigma_1^{-1} \sigma_2 \sigma_3^{-1} \sigma_4^{-1} \sigma_5 \sigma_2 \sigma_3^{-1} \sigma_4^{-1} \sigma_2^2 \sigma_3^{-1} \sigma_2 \sigma_1$ $\sigma_2 \sigma_3^2 \sigma_4^{-1} \sigma_5^{-1} \sigma_2 \sigma_3^{-1} \sigma_4 \sigma_3 \sigma_2$	3	$[2^{-1} 3^{-1} 1^{-2} 3^{-1} 2^{-2} 3^{-1} 1^{-2} 3^{-1} 2^{-1} 3 1^{-1} 3]; [\delta_2 3 1^2 3 2 3 1^2 3 \delta_2 1^{-3}]; [1^3$ $3 1^2 3 2^{-1} 3^{-1} 1^{-2} 3^{-1} 2^{-1} 3 1^2 \delta_2^{-1} 1^2 \delta_1 1^2 3 1^3 2^{-1}]$	$\delta_{PSL(2,7)} = 1$

Theorem B.1 was explained, and originally its proof was included in [St6]. There were, though, some editorial (length) concerns, so that the proof had to be moved out. The first author proposes now to give a proof in this second appendix.

We will use the explanation on Vassiliev invariants before and in the proof of Theorem 1.1. Call a (Vassiliev) invariant v *symmetric* resp. *antisymmetric* if $v(K) = v(!K)$ resp. $v(K) = -v(!K)$ for all knots K , where $!K$ is the mirror image of K . Call it *primitive* if v is additive under connected sum, i.e. $v(K_1 \# K_2) = v(K_1) + v(K_2)$ for all knots K_1 and K_2 .

Proof of Theorem B.1. Let $K_1 = 14_{41721}$ and $K_2 = 14_{42125}$ be the knots from Figure 2. They differ by a staple turn (see proof of Theorem 4.2). As we noted, the useful feature of this operation is that it is *not* a mutation in general, yet it preserves the CJP. For given n , consider first the knots

$$\mathcal{N}_n := \{ \#^k K_1 \# \#^l K_2 : k + l = n - 1 \}.$$

These, too, are interconvertible by staple turns, and thus have the same CJP. They are composite, but serve as the basis for our hyperbolic examples constructed later. The exclusion of mutation among the knots in \mathcal{N}_n follows from their connected sum decomposition, but this will not help us for the hyperbolic examples we like. Instead we use some essential arguments based on Vassiliev invariant theory.

We need now a Vassiliev invariant x of the below sort.

Lemma B.2. *There is a Vassiliev knot invariant x with the following properties:*

- x is primitive,
- x distinguishes 14_{41721} and 14_{42125} , and
- x is determined by the HOMFLY and Kauffman polynomial and their 2-satellites.

Proof. We recall from the proof of Theorem 1.1 the Vassiliev invariants $P_{k,j}$ of the HOMFLY polynomial, given (under slight change in variables) by (5). The degree of such an invariant is $\deg P_{k,j} \leq k + j$.

Let $W_+(K)$ be the untwisted (0-framed) Whitehead double of K with positive clasp. The dualization of this operation on Vassiliev invariants is an endomorphism. It preserves each space \mathcal{V}_i (defined above the proof of Theorem 1.1), a property which is equivalent to the inequality (6). Moreover, this endomorphism acts nilpotently on \mathcal{V}_i . So for many Vassiliev invariant w , the invariant $v(K) := w(W_+(K))$ makes (6) strict. Now this difference in degree will become relevant, and we should stress that even when we apply w on Whitehead doubles, d_w is meant to be the degree of $w(K)$ as a Vassiliev invariant of K , and not as an invariant $K \mapsto w(W_+(K))$.

We mentioned that the difference between the two Whitehead double HOMFLY polynomials $P_{w+}(14_{41721})$ and $P_{w+}(14_{42125})$ from Table 1 is accounted for by a Vassiliev invariant of degree ≤ 11 , e.g. $P_{2,9}$.

Now the identity (7) has the following consequence: when j is odd, the invariant $PW_{k,j}(K) := P_{k,j}(W_+(K))$ is symmetric (and antisymmetric when j is even). It follows then from [St4] that $d := \deg PW_{k,j}$ is even (resp. odd). Now $d \leq k + j$, but by parity we have $d < k + j$ (showing all $w = P_{k,j}$ as instances of strict inequality (6)). Let $v = PW_{2,9}$. So its degree is $d_v \leq 10$.

Fix bases $\{x_{i,j}\}_j$ for the spaces of primitive degree i invariants. The $x_{i,j}$ are determined up to \mathcal{V}_{i-1} and up to linear automorphisms of \mathcal{X}_i . By [St4], one can choose all invariants $x_{i,j}$ to be antisymmetric for i odd and symmetric for i even. Now, by the work of Kontsevich and Drinfel'd (see [BN]), we can write

$$(9) \quad v = X(x_{i,j}),$$

where $X \in \mathbb{Q}[x_{i,j}]$ is a polynomial. Moreover, $d_v = \deg X$, where latter is counted by $\deg x_{i,j} = i$.

In the polynomial on the right of (9) the invariants $x_{i,j}$ with maximal $i = d_v \leq 10$ occur in one-variable monomials. We may thus sum them up, and without loss of generality assume there is a single one-variable monomial $x_{d_v,j}$, which we denote by \tilde{v} . Since v is symmetric, X has only even-degree parts. We see that $v - \tilde{v}$ has degree ≤ 8 , and thus by a verification made in [St5] it is determined by HOMFLY and Kauffman and their 2-cables. Since v is determined by Whitehead double HOMFLY, \tilde{v} is determined by P , F and their 2-satellites.

If \tilde{v} distinguishes K_1 and K_2 , it is the invariant x we sought. Otherwise, since v does, $v - \tilde{v}$ must do, and thus some $x_{i,j}$ in X with $i \leq 8$. Again by [St5], this $x_{i,j}$ is determined by P , F and their 2-cables, so we can take it as the invariant we claimed. \square

Of course it would be easier if we could write x down directly, but we must provide some argument to compensate for an unmanageable calculation (in the required degree and crossing number). The established properties in Lemma B.2 imply that x excludes the mutation among the knots in \mathcal{N}_n , but we prepared it for what we really like.

Now consider the knots $K_{k,l,m}$, obtained by changing $K_{k,l} = \#^k K_1 \# \#^l K_2$ by a pretzel tangle $Y_m = (-m, m)$ with m odd, as in figure 11 (we showed it for $k = l = 1, m = 3$). Let us fix $n = k + l + 1$.

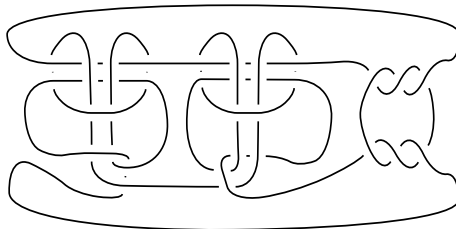

$K_{1,1,3}$

Figure 11

Now for fixed k, l , the map $M_{k,l}(m) := x(K_{k,l,m})$ is a polynomial in m . (This is an argument used also in the proof of Theorem 1.1.) Moreover, for fixed $m = \pm 1$, as observed, the values $M_{k,l}(m)$ are distinct over all k, l with $k + l = n - 1$, and thus all $M_{k,l}$ are distinct polynomials. Then for each n , when m is large enough, x will distinguish (and exclude mutation among) all knots in

$$\mathcal{N}_{n,m} := \{ K_{k,l,m} : k + l = n - 1 \}.$$

But all knots in $\mathcal{N}_{n,m}$ have the same CJP, since they are interconvertible by mutations and staple turns.

The primeness proof of $K_{k,l,m}$ is easy using the criterion in [KLc]. For hyperbolicity, one must exclude $K_{k,l,m}$ to be torus or satellite. The first is excluded because $K_{k,l,m}$ are ribbon. It requires a bit more work to exclude the second, and we apply arguments following the account in [St7, St8].

Using again the tangle decomposition, one can do induction on $k + l$. One needs some moving argument for an essential torus out of the Conway sphere of the tangle decomposition, and this can be achieved by an enhancement of the techniques in [KLc].

The knots $K = K_{k,l,m}$ naturally admit a tangle decomposition

$$(10) \quad K = T_{1,2} \cup \cdots \cup T_{1,2} \cup Y_m.$$

Here $T_{1,2}$ means ‘ T_1 or T_2 ’ for tangles T_i closing to K_i . We keep the choice $i = 1, 2$ free for each occurrence (though we must take k times $i = 1$ and l times $i = 2$). The tangle Y_m for $m \geq 3$ odd is as before the $(-m, m)$ -pretzel tangle. In the example of figure 11, the decomposition is $K_{1,1,3} = T_1 \cup T_2 \cup Y_3$.

We prove that $K_{k,l,m}$ are hyperbolic inductively over $k + l$. First, by Thurston’s surgery theorem, when k, l are fixed, we can conclude that $K_{k,l,m}$ is hyperbolic for large m , provided the limit link is hyperbolic. This link is obtained by replacing Y_m in (10) by a $(-2, 2, -2, 2)$ -pretzel tangle. By checking the hyperbolicity of a few limit links directly by SnapPea, we know there is an $m' \geq 3$ such that for all $m \geq m'$, the knot $K_{k,l,m}$ is hyperbolic when, say, $1 \leq k + l \leq 3$. It is enough to (and we do) consider only such m .

Now let $k + l \geq 4$. We can derive a tangle decomposition $K = K_{k,l,m} = X_1 \cup X_2$ from (10) letting $X_1 = T_{1,2} \cup T_{1,2}$ and $X_2 = T_{1,2} \cup \cdots \cup T_{1,2} \cup Y_m$. Let B_i be the balls of X_i .

An essential torus T of K (which is *a fortiori* knotted) can be made to intersect the balls B_i in annuli A . Furthermore, for each such annulus, ∂A bounds two disks D on the Conway sphere $C = \partial B_i$, such

that these disks are meridional in T , and either D contain 2 of the punctures $K \cap C$. (Otherwise K is composite or T is ∂ -parallel.)

If all annuli of $T \cap B_i$ are unknotted, they can be successively removed, so $T \cap C = \emptyset$. A torus $T \subset B_i$ remains essential if we replace X_1 by $T_{1,2}$ (if $i = 2$) or X_2 by $T_{1,2} \cup Y_m$ (if $i = 1$): T is not ∂ -parallel, because it is not separating, and a meridional disk (on C) has geometric intersection number 2 with K . Since the tangles T_i and Y_m are prime (in the sense of [KLc]), T will not compress either after replacing tangles. So we have a contradiction to the induction assumption.

Thus we may assume $T \cap B_i$ contains knotted annuli for both $i = 1, 2$. Since both X_i have an unknotted string, it follows that each meridional disk of $T \cap C$ contains the endpoints of the same string of X_i for either $i = 1, 2$. But then $K = X_1 \cup X_2$ is a 2-component link, a contradiction.

With this the hyperbolicity of $K = K_{k,l,m}$ is established, and the proof of Theorem B.1 is complete. \square

REFERENCES

- [Ad] C. C. Adams, *Thrice-punctured spheres in hyperbolic 3-manifolds*, Trans. Am. Math. Soc. **287** (1985), 645–656.
- [BN] D. Bar-Natan, *On the Vassiliev knot invariants*, Topology **34** (1995), 423–472.
- [BN2] ———, *KnotTheory*, Mathematica Package for calculation of knot invariants, available at <http://www.math.toronto.edu/~drorbn/KAtlas/>.
- [BG] ——— and S. Garoufalidis, *On the Melvin-Morton-Rozansky Conjecture*, Invent. Math. **125** (1996), 103–133.
- [BHMV] C. Blanchet, N. Habegger, G. Masbaum and P. Vogel, *Three-manifold invariants derived from the Kauffman bracket*, Topology **31** (1992), 685–699.
- [BLM] R. D. Brandt, W. B. R. Lickorish and K. Millett, *A polynomial invariant for unoriented knots and links*, Inv. Math. **74** (1986), 563–573.
- [Ch] S. Chmutov, S. *A proof of the Melvin-Morton conjecture and Feynman diagrams*, J. Knot Theory Ramifications **7(1)** (1998), 23–40.
- [Co] J. H. Conway, *On enumeration of knots and links*, in “Computational Problems in abstract algebra” (J. Leech, ed.), 329–358. Pergamon Press, 1969.
- [CL] D. Cooper and W. B. R. Lickorish, *Mutations of links in genus 2 handlebodies*, Proc. Amer. Math. Soc. **127(1)** (1999), 309–314.
- [CM] P. R. Cromwell and H. R. Morton, *Distinguishing mutants by knot polynomials*, Jour. of Knot Theory and its Ramifications **5(2)** (1996), 225–238.
- [DG] N. M. Dunfield and S. Garoufalidis, *Non-triviality of the A-polynomial for knots in S^3* , Algebr. Geom. Topol. **4** (2004), 1145–1153 (electronic).
- [DGST] ———, ———, A. Shumakovich and M. Thistlethwaite, *Behavior of knot invariants under genus 2 mutation*, preprint math.GT/0607258.
- [F&] P. Freyd, J. Hoste, W. B. R. Lickorish, K. Millett, A. Ocneanu and D. Yetter, *A new polynomial invariant of knots and links*, Bull. Amer. Math. Soc. **12** (1985), 239–246.
- [G] GAP, a system for computational discrete algebra, available at <http://www.gap-system.org/>.
- [Ga] S. Garoufalidis, *Does the Jones polynomial determine the signature of a knot?*, preprint math.GT/0310203.
- [Ga2] ———, *On the characteristic and deformation varieties of a knot*, Proceedings of the Casson Fest, 291–309, Geom. Topol. Monogr. **7**, Geom. Topol. Publ., Coventry, 2004.
- [Ho] C. F. Ho, *A polynomial invariant for knots and links – preliminary report*, Abstracts Amer. Math. Soc. **6** (1985), 300.
- [HT] J. Hoste and M. Thistlethwaite, *KnotScape*, a knot polynomial calculation and table access program, available at <http://www.math.utk.edu/~morwen>.
- [J] V. F. R. Jones, *A polynomial invariant of knots and links via von Neumann algebras*, Bull. Amer. Math. Soc. **12** (1985), 103–111.
- [Ka] L. H. Kauffman, *An invariant of regular isotopy*, Trans. Amer. Math. Soc. **318** (1990), 417–471.
- [Ki] C. King, *A relationship between the Jones and Kauffman polynomials*, Trans. Amer. Math. Soc. **329(1)** (1992), 307–323.
- [Kr] R. Kirby (ed.), *Problems of low-dimensional topology*, book available on <http://math.berkeley.edu/~kirby>.
- [KLc] ——— and W. B. R. Lickorish, *Prime knots and concordance*, Math. Proc. Cambridge Philos. Soc. **86(3)** (1979), 437–441.
- [KL] P. Kirk and C. Livingston, *Twisted knot polynomials: inversion, mutation and concordance*, Topology **38(3)** (1999), 663–671.
- [KSA] A. Krieger, B. Spence and I. Aitchison, *Cabling the Vassiliev invariants*, Jour. of Knot Theory and its Ramifications **6** (1997), 327–358. See also q-alg/9511024.
- [LMu] T. Q. T. Le and J. Murakami, *The universal Vassiliev-Kontsevich invariant for framed oriented links*, Compos. Math. **102(1)** (1996), 41–64.
- [Li] W. B. R. Lickorish, *An introduction to knot theory*, Graduate Texts in Mathematics **175**, Springer-Verlag, New York, 1997.
- [LL] ——— and A. S. Lipson, *Polynomials of 2-cable-like links*, Proc. Amer. Math. Soc. **100** (1987), 355–361.
- [LM] ——— and K. C. Millett, *A polynomial invariant for oriented links*, Topology **26(1)** (1987), 107–141.

- [MV] G. Masbaum and P. Vogel, *3-valent graphs and the Kauffman bracket*, Pacific J. Math. **164** (1994), 361–381.
- [Me] W. W. Menasco, *Closed incompressible surfaces in alternating knot and link complements*, Topology **23** (1) (1986), 37–44.
- [MTh] ——— and M. B. Thistlethwaite, *The Tait flyping conjecture*, Bull. Amer. Math. Soc. **25** (2) (1991), 403–412.
- [MR] H. R. Morton and H. J. Ryder, *Mutants and $SU(3)_q$ invariants*, The Epstein birthday schrift, Geom. Topol. Monogr. **1**, Geom. Topol. Publ., Coventry, 1998, 365–381.
- [MR2] ——— and ———, *Invariants of genus 2 mutants*, preprint [arXiv:0708.0514](https://arxiv.org/abs/0708.0514).
- [MT] ——— and P. Traczyk, *The Jones polynomial of satellite links around mutants*, In ‘Braids’, (Joan S. Birman and Anatoly Libgober, eds.), Contemporary Mathematics **78**, Amer. Math. Soc. (1988), 587–592.
- [MM] H. Murakami and J. Murakami, *The colored Jones polynomials and the simplicial volume of a knot*, Acta Math. **186**(1) (2001), 85–104.
- [Ro] D. Rolfsen, *Knots and links*, Publish or Perish, 1976.
- [R] Yong Wu Rong, *Mutation and Witten invariants*, Topology **33**(3) (1994), 499–507.
- [Ru] D. Ruberman, *Mutation and volumes of knots in S^3* , Invent. Math. **90**(1) (1987), 189–215.
- [Si] L. Siebenmann, *On the vanishing of the Rochlin invariant and non-finitely amphicheiral homology 3-spheres*, Lecture Notes in Math. **788** (1980), 223–244.
- [SW] D. Silver and W. Whitten, *Hyperbolic covering knots*, Alg. Geom. Top. **5** (2005), 1451–1469.
- [St] A. Stoimenow, *Hard to identify (non-)mutations*, Math. Proc. Camb. Phil. Soc. **141**(2) (2006), 281–285.
- [St2] ———, *Gauß sum invariants, Vassiliev invariants and braiding sequences*, J. Of Knot Theory and Its Ram. **9**(2) (2000), 221–269.
- [St3] ———, *On cabled knots and Vassiliev invariants (not) contained in knot polynomials*, Canad. J. Math. **59**(2) (2007), 418–448.
- [St4] ———, *Vassiliev invariants on fibered and mutually obverse knots*, Jour. of Knot Theory and its Ramifications **8**(4) (1999), 511–519.
- [St5] ———, *On cabled knots and Vassiliev invariants (not) contained in knot polynomials*, Canad. J. Math. **59**(2) (2007), 418–448.
- [St6] ———, *Non-mutants with equal colored Jones polynomial*, C. R. Acad. Sci. Paris, Ser. I **347** (2009), 809–811.
- [St7] ———, *Vassiliev invariants, Seifert matrix, and hyperbolic volume of knots*, Int. Math. Res. Not., Art. ID **rnn119** (2008).
- [St8] ———, *Realizing Alexander Polynomials by Hyperbolic Links*, accepted by Expos. Math.
- [St9] ———, *Tabulating and distinguishing mutants*, preprint.
- [T] T. Tanaka, *On the colored Jones polynomials of doubles of knots*, J. Knot Theory Ramifications **17**(8) (2008), 925–937.
- [Th] W. P. Thurston, *Three-dimensional geometry and topology, Vol 1*, (Silvio Levy, ed.), Princeton Mathematical Series **35**, Princeton University Press, Princeton, NJ, 1997.
- [Th2] ———, *Three-dimensional manifolds, Kleinian groups and hyperbolic geometry*, Bull. Amer. Math. Soc. (N.S.) **6** (1982), 357–381.
- [Ti] S. Tillmann, *Character varieties of mutative 3-manifolds*, Algebraic and Geometric Topology **4** (2004), 133–149 (electronic).
- [Tr] R. Trapp, *Twist sequences and Vassiliev invariants*, Jour. of Knot Theory and its Ramifications **3**(3) (1994), 391–405.
- [Va] A. Vaintrob, *Melvin-Morton conjecture and primitive Feynman diagrams*, Internat. J. Math. **8**(4) (1997), 537–553.
- [Vi] O. Ja. Viro, *Two-sheeted branched coverings of the three-sphere*, Studies in topology. Zap. Naučn. Sem. Leningrad. Otdel. Mat. Inst. Steklov. (LOMI) **36** (1973), 6–39.
- [Y] S. Yamada, *An operator on regular isotopy invariants of link diagrams*, Topology **28**(3) (1989), 369–377.